



19011439A02

Copyright © Shenzhen Inovance Technology Co., Ltd.

**Monarch**  
by INOVANCE

FORWARD, ALWAYS PROGRESSING



## Tomorrow Series Integrated Elevator Control Cabinet Electrical Schematic Diagrams

**Shenzhen Inovance Technology Co., Ltd.**

www.inovance.com

Add.: Inovance Headquarters Tower, High-tech Industrial Park,  
Guanlan Street, Longhua New District, Shenzhen

Tel: (0755) 2979 9595 Fax: (0755) 2961 9897

**Suzhou Inovance Technology Co., Ltd.**

www.inovance.com

Add.: No. 16 Youxiang Road, Yuexi Town,  
Wuzhong District, Suzhou 215104, P.R. China

Tel: (0512) 6637 6666 Fax: (0512) 6285 6720



Industrial  
Automation



Intelligent  
Elevator



New Energy  
Vehicle



Industrial  
Robot



Rail  
Transit



Data code 19011439 A02





## Contents

Contents / Revision History .....	3
List of Component Codes.....	4
Process Standards .....	5
List of Parameters .....	6
List of Parameters .....	7
Power Distribution Box of the MR Elevator.....	8
Main Circuit of the MR Elevator.....	9
Main Circuit of the MRL Elevator.....	10
Control Power Supply Circuit .....	11
Brake Circuit .....	12
Safety Circuit and Door Lock Circuit .....	13
Contactor Control and Feedback Circuits .....	14
EEO and Car Top Inspection Circuits.....	15
Lighting Circuits of the MR Elevator .....	16
Lighting Circuits of the MRL Elevator .....	17
Overspeed Governor EEO Circuit of the MRL Elevator.....	18
Electric Brake Release Circuit of the MRL Elevator.....	19
Car Top Inspection Box Control Circuit.....	20
Intercoms, Alarms and Emergency Indicators.....	21
Operation Box Control Circuit.....	22
General Wiring Diagram .....	23
Machine Room Wiring Diagram .....	24
Car Top Wiring Diagram .....	25
Shaft Wiring Diagram .....	26
Pit Wiring Diagram.....	27
Layout of the MCB .....	28
Wiring Between the MCB and Internal Devices .....	29
Wiring Between the MCB and Peripheral Devices .....	30
Car Top Integrated Wiring .....	31
Parallel Connection Circuit .....	32
Three-phase 380 V ARD Circuit .....	33
IoT Module.....	34
Protocol Conversion Board.....	35
I/O Expansion Board .....	36

## Revision History

Date	Change Description	Version
September 2022	Establish the new parallel connection between the monitoring room intercom (connection with the pit intercom removed) and machine room intercom.	A02
October 2021	<ol style="list-style-type: none"> <li>1. Add a terminal block under the high-power SW contactor;</li> <li>2. Change the cooling fan module position from the brake power supply board to the driver board</li> </ol>	A01
August 2020	First release.	A00

## List of Component Codes

Code	Position	Meaning
1BFS	HTW	Buffer switch 1
2BFS	HTW	Buffer switch 2
ALB	CAR	Alarm button
ATS	CAR	Attendant/Normal state switchover switch
BM	CTR	Brake coil
BY	CTR	Brake contactor
COB	CAR	Command distribution board
CCB	CAR	Command expansion board
CES	CAR	Car stop switch
CHM	CAR	Voice announcer
CLI	CAR	Car lighting
CLIS	CAR	Car lighting switch
CLT1	CAR	Door 1 close limit
CLT2	CAR	Door 2 close limit
CTB	CAR	Car top board (CTB)
CIS	CTR	Emergency electric operation (EEO) switch
RUN	CTR	EEO button
UP	CTR	EEO up button
DOWN	CTR	EEO down button
DBR	CAR	Braking resistor
DCB1	CAR	Door 1 close command
DCB2	CTR	Door 2 close command
DDCB	CAR	Door open delay button
DLS1	HTW	Down slow-down 1
DLS2	HTW	Down slow-down 2
DM	CAR	Door operator motor
DOB1	CAR	Door 1 open command
DOB2	CAR	Door 2 open command
DS	HTW	Electrical linkage switch of landing door lock

Code	Position	Meaning
DZD	CAR	Down leveling switch
DZU	CAR	Up leveling switch
DP	CAR	Door operator over-temperature protection
ECL	CAR	Car emergency lighting
EDP1	CAR	Door 1 light curtain
EDP2	CAR	Door 2 light curtain
ECB	CAR	Alarm
F1	CTR	Door operator brake circuit fuse
F2	CTR	Safety circuit fuse
F3	CTR	Car lighting circuit fuse
FAN	CAR	Car fan
FIRS2	CAR	Firefighter switch (operation box)
FLSD	HTW	Down final limit switch
FLSU	HTW	Up final limit switch
FS	CAR	Car fan switch
FX	CTR	Shorting motor stator contactor
GS	CTR	Car door lock switch
GTS	CAR	Broken rope switch on the tension pulley
HCB	HTW	Floor display board
ISS	HTW	Independent running switch
LIHS1	CAR	Shaft lighting switch in the machine room
LIHS2	HTW	Shaft lighting switch in the pit
LPT	HTW	Arrival gong
LWO	CAR	Overload switch
LWX	CAR	Full-load switch
MCB	CAR	Main control board (MCB)
MES	CTR	Control cabinet stop button

Code	Position	Meaning
MES-1	CTR	Motor stop button
MES-2	MR	Hand wheel stop button
MTS	MR	Motor over-temperature protection
NSB	MR	Direct travel ride switch for attendant
OLT1	CAR	Door 1 open limit
OLT2	HTW	Door 2 open limit
QS	HTW	Overspeed governor electrical switch
PES1	HTW	Pit inspection box stop button
PES2	HTW	Pit switch box stop button
PG	HTW	Encoder (traction machine)
PLI	MR	Pit light
PUR	HTW	Pit socket
QFB3	CTR	Residual current device (RCD) for car lighting circuit
QFB4	CTR	RCD for shaft lighting circuit
QF	CTR	Air switch
RCS	MR	Rope gripper electrical switch
RRB	CTR	Overspeed governor remote release button
RRD	HTW	Overspeed governor remote release coil
RS	CTR	Forced inspection relay
RTB	CTR	Overspeed governor remote action button
RTD	HTW	Overspeed governor remote action coil
S1	CTR	Bypass circuit terminal
S2	CAR	Control cabinet lighting switch on the car top inspection box

Code	Position	Meaning
S3	CAR	Car top lighting switch
SUP	CAR	Backup safety circuit switch
SOS	CTR	Safety gear action electrical switch
SW	CTR	RUN contactor
SWP	CTR	Switched-mode power supply
SGS	CAR	Auxiliary door lock on the car top
SWP	CTR	Switched-mode power supply
FL1	CAR	Up door zone switch
FL2	CAR	Down door zone switch
BZ	CAR	Sound and light alarm device
TCI	CAR	Car top inspection knob
TCIB	CAR	Car top inspection common button
TCID	CAR	Car top inspection down button
TCIU	CAR	Car top inspection up button
TES	CAR	Car top stop button
TLS	CAR	Car top lighting switch
TECL	CAR	Car top inspection light
TRF	CTR	Control transformer
TUR1	CAR	Car top socket (220 VAC)
ULS1	HTW	Up slow-down 1
ULS2	HTW	Up slow-down 2
WT1	CAR	Digital load cell
WT2	CAR	Analog load cell
CAR	NULL	Car
CTR	NULL	Control cabinet
MR	NULL	Motor
HTW	NULL	Shaft

## Process Standards of Electrical Schematic Diagrams

### 1. Naming rules of the main power supply

The five cables of three-phase 380 V motive power in the front and rear stages of the main air switch are named L1, L2, L3, N and PE, and R, S, T, N1 and PE, respectively.

### 2. Naming rules of the control power supply

110 VAC: 101, 102; range: 101–199

220 VAC: 201, 202; range: 201–299

24 VDC: 301, 302; range: 301–399

110 VDC: L+, L-

### 3. Naming rules of the lighting power supply

Car top 220 V lighting power supply in the rear stage of the RCD in the power supply cabinet: 501 and 502, range: 501–599

Shaft 220 V lighting power supply in the rear stage of the control switch in the power supply cabinet: 807, 809 and 802, range: 801–810

### 4. Naming rules of circuit No.

101–199: AC safety circuit-related circuits

201–299: 220 VAC control-related circuits

301–399: 24 VDC-related circuits

501–599: 220 VAC lighting-related circuits

801–810: 220 VAC shaft lighting-related circuits

### 5. Operation rules of switches and contacts

All switches, relays and contactor contacts are top-open and bottom-closed or left-open and right-closed.

### 6. This document applies to the modular control cabinets manufactured by Inovance.

### 7. Application range of electrical schematic diagrams:

The electrical schematic diagrams are applied to control cabinets supporting both synchronous and asynchronous motors.

If an asynchronous motor is used, you need not add the components and circuits with the information "added if a synchronous motor is used" in the diagrams.

## List of Parameters

Parameter No.	Parameter Name	Setting Value	Parameter No.	Parameter Name	Setting Value	Parameter No.	Parameter Name	Setting Value
F0-00	Control mode	1	F5-01	X1 function selection	1: Up leveling normally open (NO)	F5-18	X18 function selection	58: Brake travel switch 1 NC
F0-01	Command source selection	1	F5-02	X2 function selection	0	F5-19	X19 function selection	0
F0-03	Running speed	Model dependent	F5-03	X3 function selection	2: Down leveling NO	F5-20	X20 function selection	99: Motor over-temperature NC
F0-04	Rated speed	Model dependent	F5-04	X4 function selection	118: Door lock bypass input normally closed (NC)	F5-21	X21 function selection	0
F0-05	Rated load	Model dependent	F5-05	X5 function selection	0	F5-22	X22 function selection	110: Brake travel switch 2 NC
F1-00	Encoder type	0: Sin/Cos encoder (synchronous motor) 1: UVW encoder (synchronous motor) 2: ABZ encoder (asynchronous motor) 3: ECN413/1313 absolute encoder 4: Weton EA53 communication encoder	F5-06	X6 function selection	38: RUN contactor output feedback NC	F5-23	X23 function selection	0
F1-01	Rated power	Model dependent	F5-07	X7 function selection	39: Brake control output feedback NC	F5-24	X24 function selection	0
F1-02	Rated voltage	Model dependent	F5-08	X8 function selection	30: Shorting motor stator control output feedback NO	F5-25	CTB input type	1856 (Bit6, Bit8, Bit9 and Bit10 are set to 1)
F1-03	Rated current	Model dependent	F5-09	X9 function selection	116: EEO input NC	F5-26	Y1 function selection	1: RUN contactor output
F1-04	Rated frequency	Model dependent	F5-10	X10 function selection	09: EEO up NO	F5-27	Y2 function selection	2: Brake control output
F1-05	Rated speed	Model dependent	F5-11	X11 function selection	10: EEO down NO	F5-28	Y3 function selection	12: Shorting motor stator control output
F1-11	Auto-tuning mode	1: With-load auto-tuning 2: No-load auto-tuning 3: Shaft auto-tuning	F5-12	X12 function selection	0	F5-29	Y4 function selection	4: Fire emergency floor arrival signal feedback
F1-12	Encoder pulses per revolution (PPR)	Model dependent	F5-13	X13 function selection	0	F5-30	Y5 function selection	0
F1-25	Motor type	0: Asynchronous motor 1: Synchronous motor	F5-14	X14 function selection	48: Up slow-down 1 NC	F5-31	Y6 function selection	0
F2-10	Elevator running direction	0: Running direction unchanged 1: Running direction reversed	F5-15	X15 function selection	49: Down slow-down 1 NC	F5-36	Load cell input selection	0: MCB digital input 1: CTB digital input 2: CTB analog input 3: MCB analog input
F3-25	EEO speed	0.25	F5-16	X16 function selection	50: Up slow-down 2 NC	F5-37	X25 function selection	4: Safety circuit signal
F3-26	Shaft auto-tuning speed	0.25	F5-17	X17 function selection	51: Down slow-down 2 NC			

## List of Parameters

Parameter No.	Parameter Name	Setting Value
F5-38	X26 function selection	7: Door 1 lock shorting signal
F5-39	X27 function selection	5: Door lock circuit signal
F5-40	X28 function selection	8: Door 2 lock shorting signal (set for double-door elevators)
F6-00	Top floor of the elevator	Based on actual conditions
F6-01	Bottom floor of the elevator	Based on actual conditions
F6-40	Program control selection 1	Bit1 = 1: Software limit function
F6-52	Function selection	Bit1 = 1: Supports MCTC-SCB-A4/D4 Bit6 = 1: CAN communication leveling signal
F8-01	Pre-torque selection	2: Automatic pre-torque compensation
F8-10	Emergency evacuation power supply at power failure	1: Emergency evacuation by automatic rescue device (ARD) (optional)
Fb-00	Number of door operator(s)	1: Single entrance car 2: Through type car

Parameter No.	Parameter Name	Setting Value
Fb-02	Service floor 1 of door operator 1	
Fb-03	Service floor 2 of door operator 1	Set based on actual conditions (binary): Bit0 = 1, Bit1 = 2, Bit2 = 4, Bit3 = 8, Bit4 = 16, Bit5 = 32, Bit6 = 64, Bit7 = 128, Bit8 = 256, Bit9 = 512, Bit10 = 1024, Bit11 = 2048, Bit12 = 4096, Bit13 = 8192, Bit14 = 16384, Bit15 = 32768
Fb-18	Service floor 3 of door operator 1	
Fb-04	Service floor 1 of door operator 2	
Fb-05	Service floor 2 of door operator 2	Service floors 1, 2 and 3 are set in the same way as F6-05, F6-06 and F6-35.
Fb-19	Service floor 3 of door operator 2	
FC-04	Double-door control selection	0: Door open/close on both sides if the car/hall call is active on either side 1: Door open on the same side if the hall call is active, and door open on both sides if the car call is active 2: Door open on the same side if the hall call is active, and door open only on one side if the car call is active (manual selection) 3: Door open on the same side if the car/hall call is active
F2-33	Torque amplitude	50% to 150% of the rated motor torque
F6-07	Number of elevators in group control	Based on actual conditions
F6-08	Elevator No.	Group control: elevator No. set based on actual conditions Parallel control: 1 as the master elevator and 2 as the slave elevator
F6-09	Program selection	Bit3 = 1: Parallel/group control via CAN2

Parameter No.	Parameter Name	Setting Value
F8-16	Start address of hall call auxiliary command	0-48
F6-55	Program selection	Bit11: Communication encoder enabled
Notes:		
1. The new generation of control cabinet is connected to the car top inspection box through communication. The car top inspection signal and up/down leveling signal are transmitted through communication.		
2. The up and down limits are realized through the software limit function. Therefore, the up and down limit switches are not needed.		



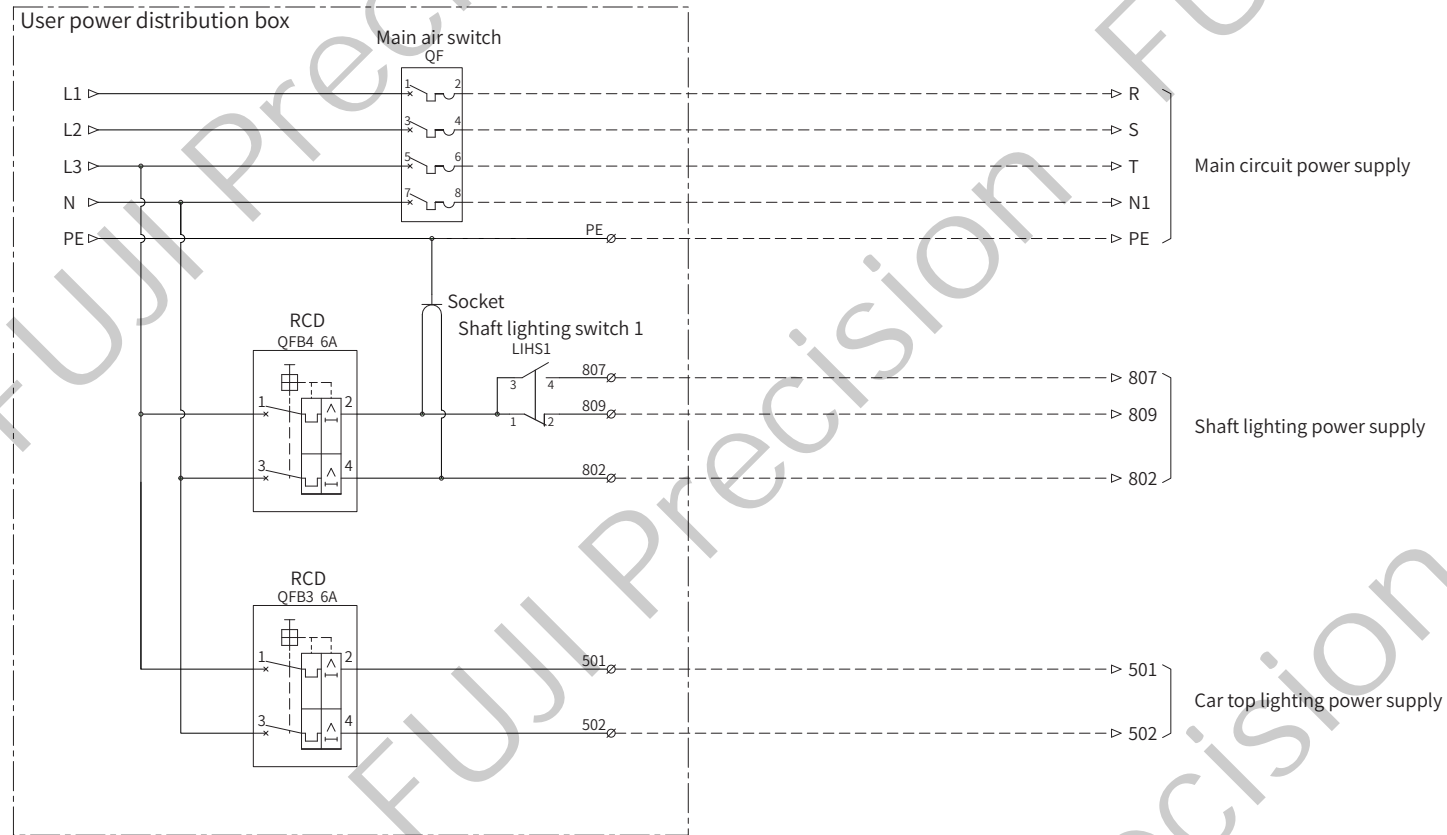

Notes:

1. The power distribution box is provided only for machine room (MR) elevators.
2. Equip the power distribution box with a 4p main switch, a car top lighting RCD, a shaft lighting RCD, a shaft lighting switch, and a socket.
3. Select RCDs with a leakage current of 30 mA for lighting circuits.
4. Select a 250 V 2P+PE socket.

Notes:

1. For a machine room-less (MRL) elevator, connect the input cables of the control cabinet to the main circuit terminals and the output (motor) cables to:
  - ① the output side of the RUN contactor in the case of asynchronous motor
  - ② the conversion terminals of contactor accessories in the case of synchronous motor
2. Install the braking resistor separately. Connect the braking resistor cable to the P1 terminal.
3. Select a proper PG card based on the encoder type.
4. The communication encoder does not need a PG card, but a communication encoder-dedicated cable is required.  
The encoder terminal J8 is located on the right side of the main power terminal P1.

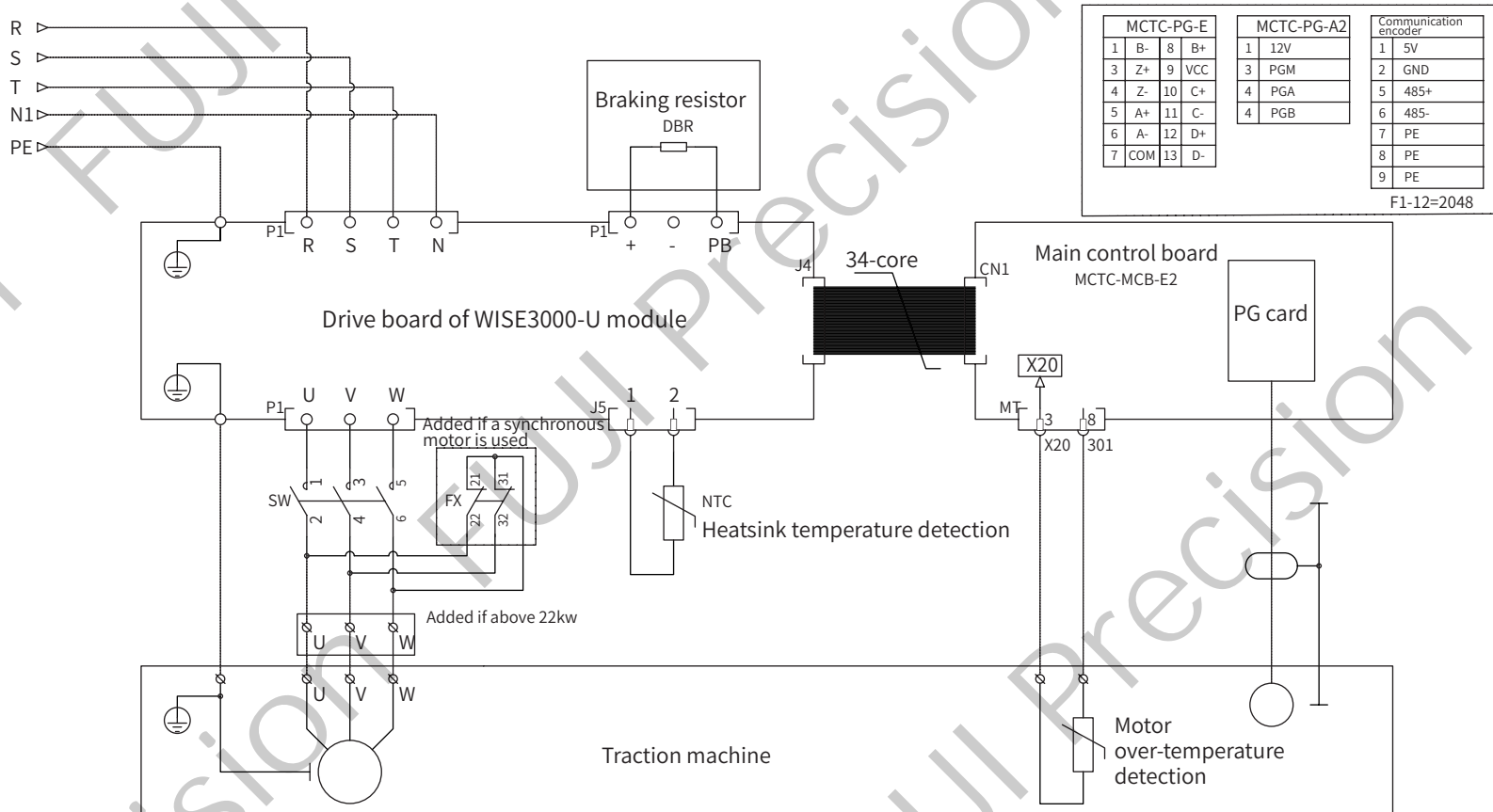

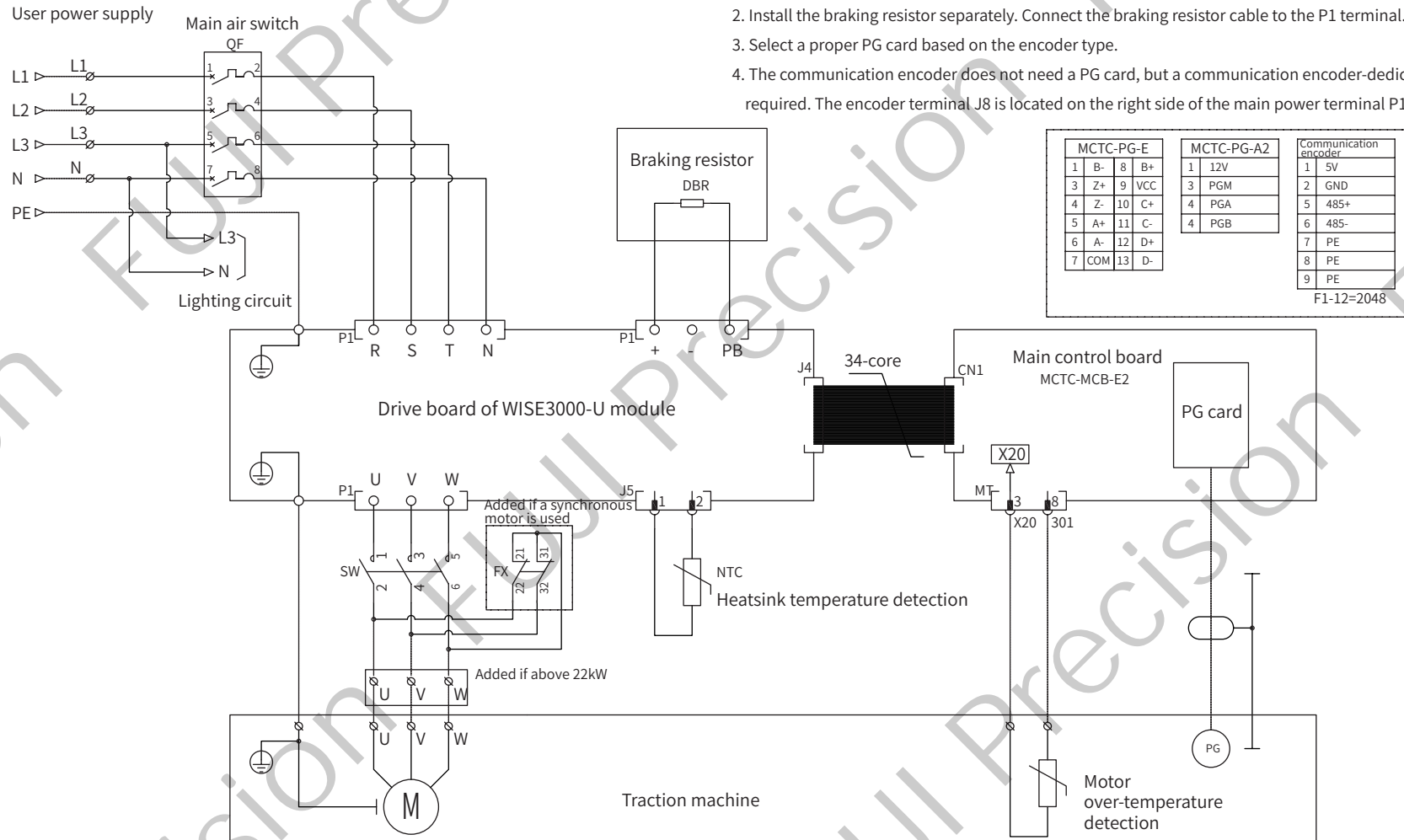

Notes:

- For a MRL elevator, connect the input cables of the control cabinet to the main circuit terminals and the output (motor) cables to:
  - the output side of the RUN contactor in the case of asynchronous motor
  - the conversion terminals of contactor accessories in the case of synchronous motor
- Install the braking resistor separately. Connect the braking resistor cable to the P1 terminal.
- Select a proper PG card based on the encoder type.
- The communication encoder does not need a PG card, but a communication encoder-dedicated cable is required. The encoder terminal J8 is located on the right side of the main power terminal P1.

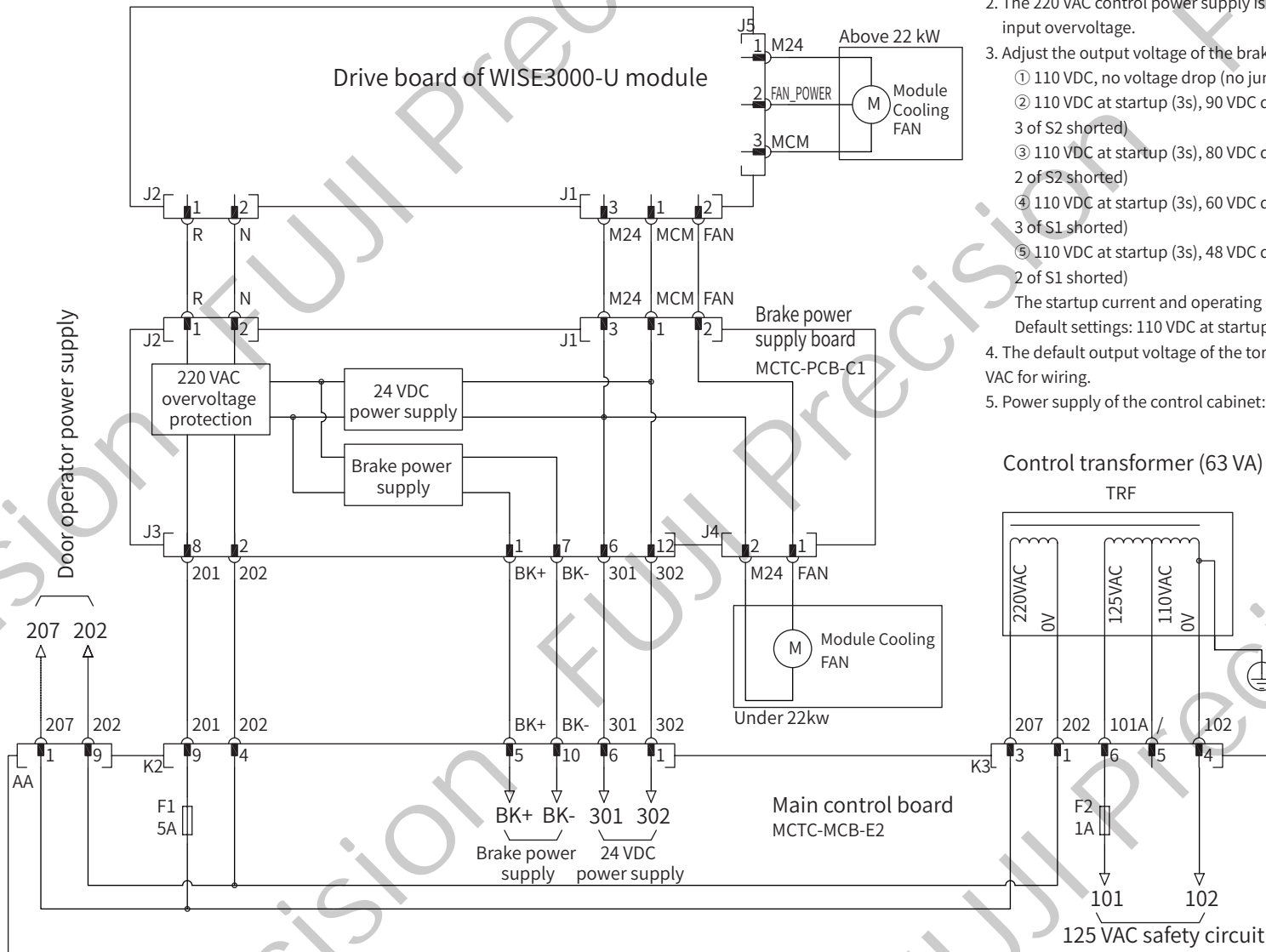

Notes:

1. The drive board can control the start and stop of the fan by cutting off 0 V power supply.
2. The 220 VAC control power supply is equipped with overvoltage protection to prevent input overvoltage.
3. Adjust the output voltage of the brake power supply using jumpers.
  - ① 110 VDC, no voltage drop (no jumper cap for both S1 and S2)
  - ② 110 VDC at startup (3s), 90 VDC during operating (no jumper cap for S1, pins 2 and 3 of S2 shorted)
  - ③ 110 VDC at startup (3s), 80 VDC during operating (no jumper cap for S1, pins 1 and 2 of S2 shorted)
  - ④ 110 VDC at startup (3s), 60 VDC during operating (no jumper cap for S2, pins 2 and 3 of S1 shorted)
  - ⑤ 110 VDC at startup (3s), 48 VDC during operating (no jumper cap for S2, pins 1 and 2 of S1 shorted)

The startup current and operating current of the brake are 6 A and 4 A respectively.  
Default settings: 110 VDC at startup (3s), 90 VDC during operating
4. The default output voltage of the toroidal isolation transformer is 125 VAC. Reserve 110 VAC for wiring.
5. Power supply of the control cabinet: 24 VDC, 120 W

Control transformer (63 VA)

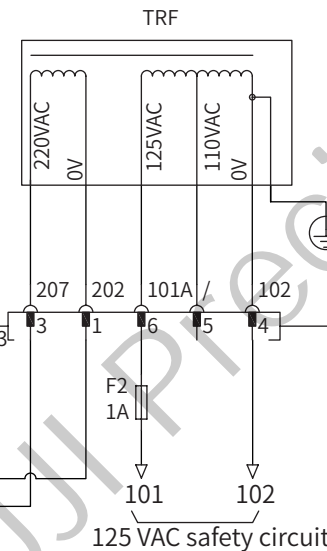

Notes:

1. Electric brake release is a standard function for MRL elevators.
2. The MCB has a built-in brake arc control device.

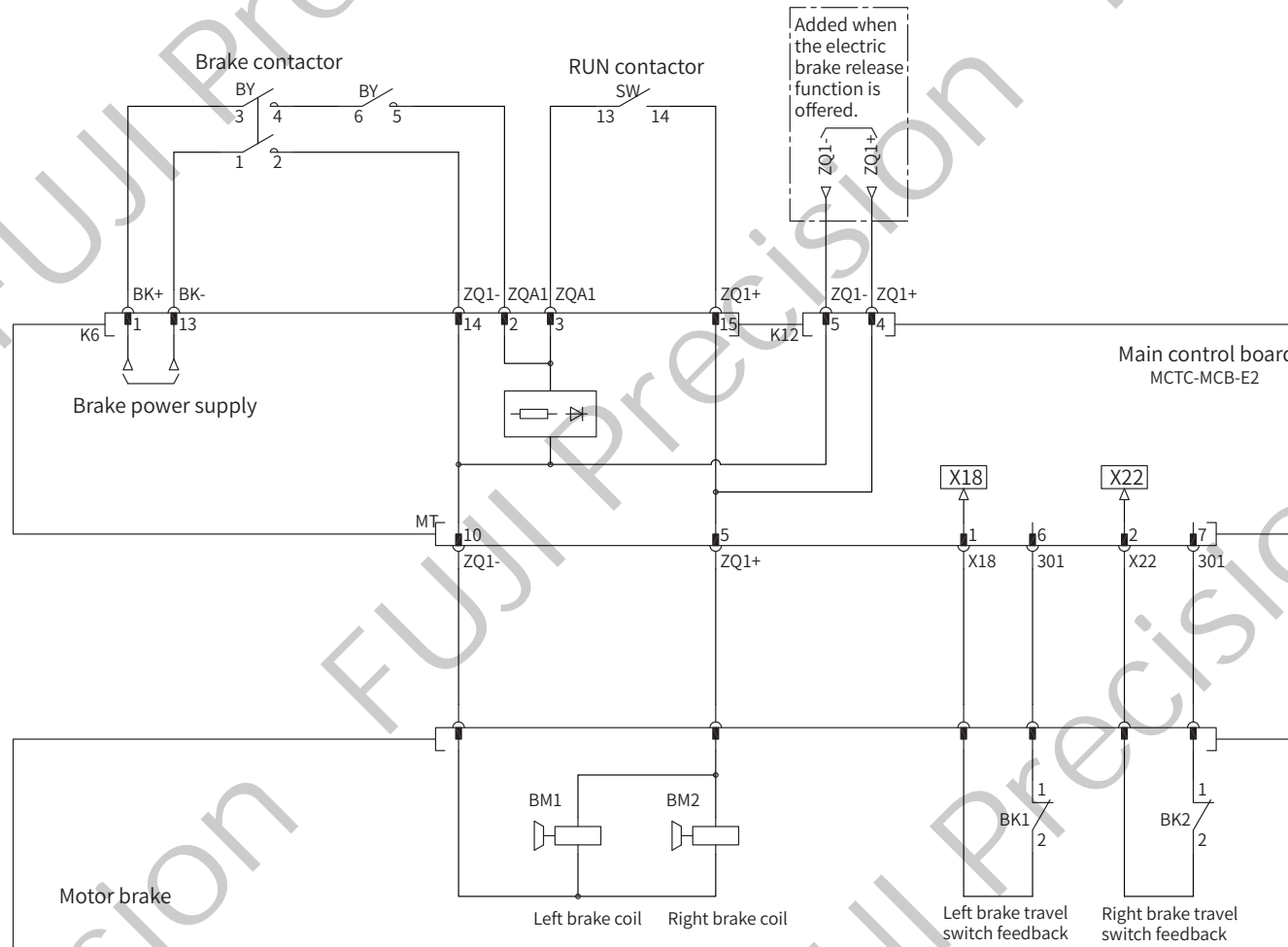

Notes:

- The configuration of the advance door opening (ADO) board is as follows:
  - Configure the MCTC-SCB-A4 for elevators with synchronous motor and single entrance car.
  - Configure the MCTC-SCB-D4 for elevators with synchronous motor and through type car.
  - Configure the MCTC-SCB-D4 for elevators with asynchronous motor.
  - If the elevator only has one door, short pins 7 and 8 on the landing door lock interface BA of door 2 and pins 6 and 14 on the car door lock interface AA of door 2.
- An unintended car movement protection (UCMP) plug is offered by default. It is used only in the UCMP test. The door lock circuits and auxiliary door lock circuits will be disconnected if you pull out this plug.
- Different indicators (111, 121, 123) are offered for the safety circuit to detect different circuit segments. If an indicator is off, the corresponding safety circuit segment is disconnected.

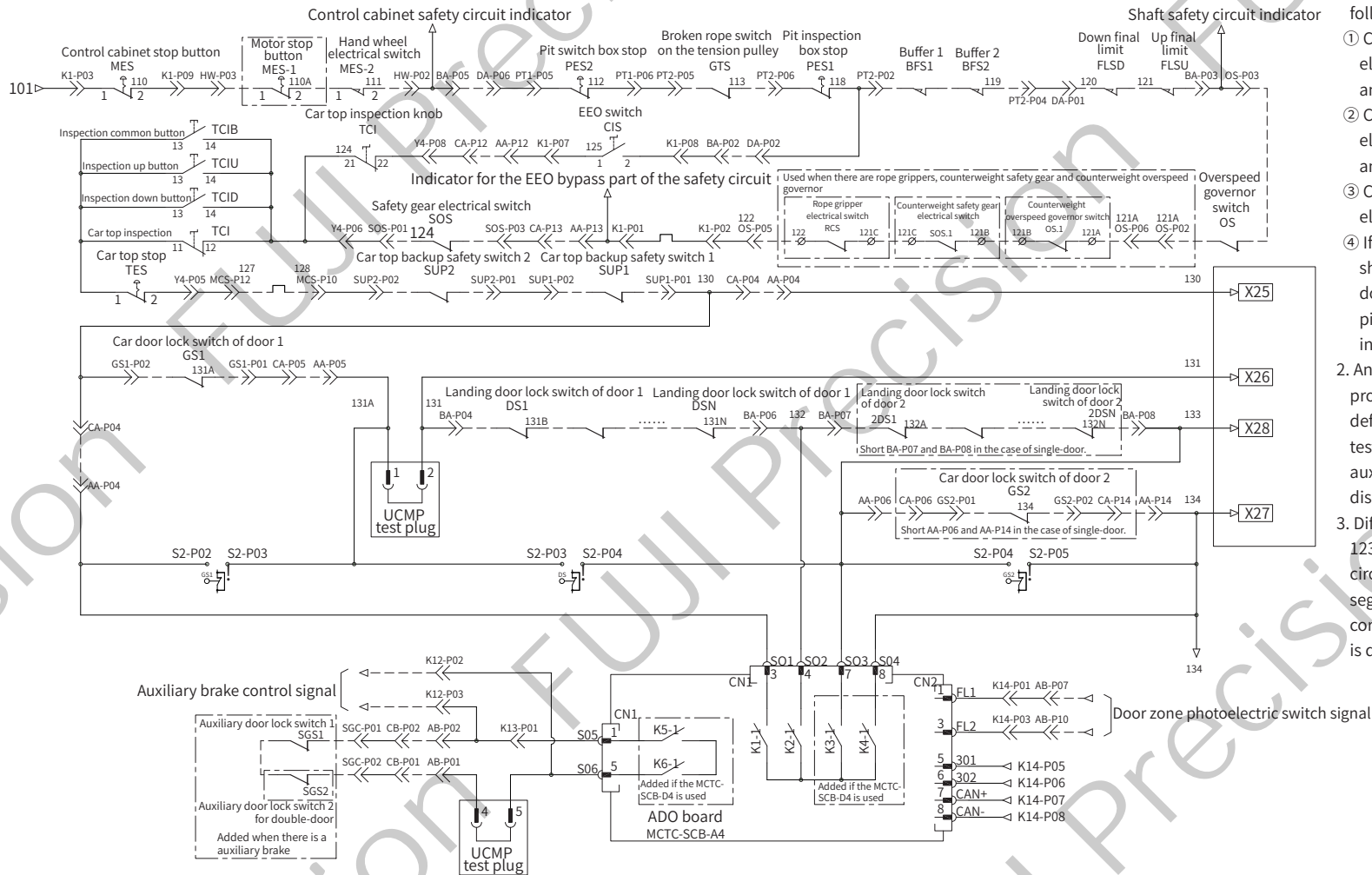

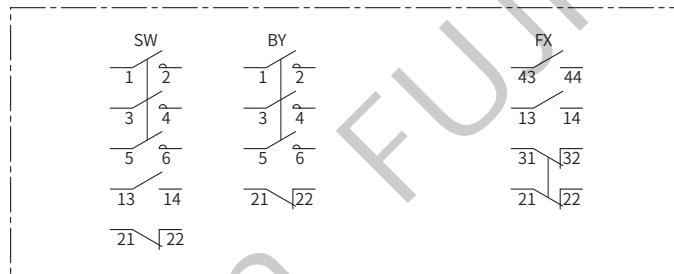
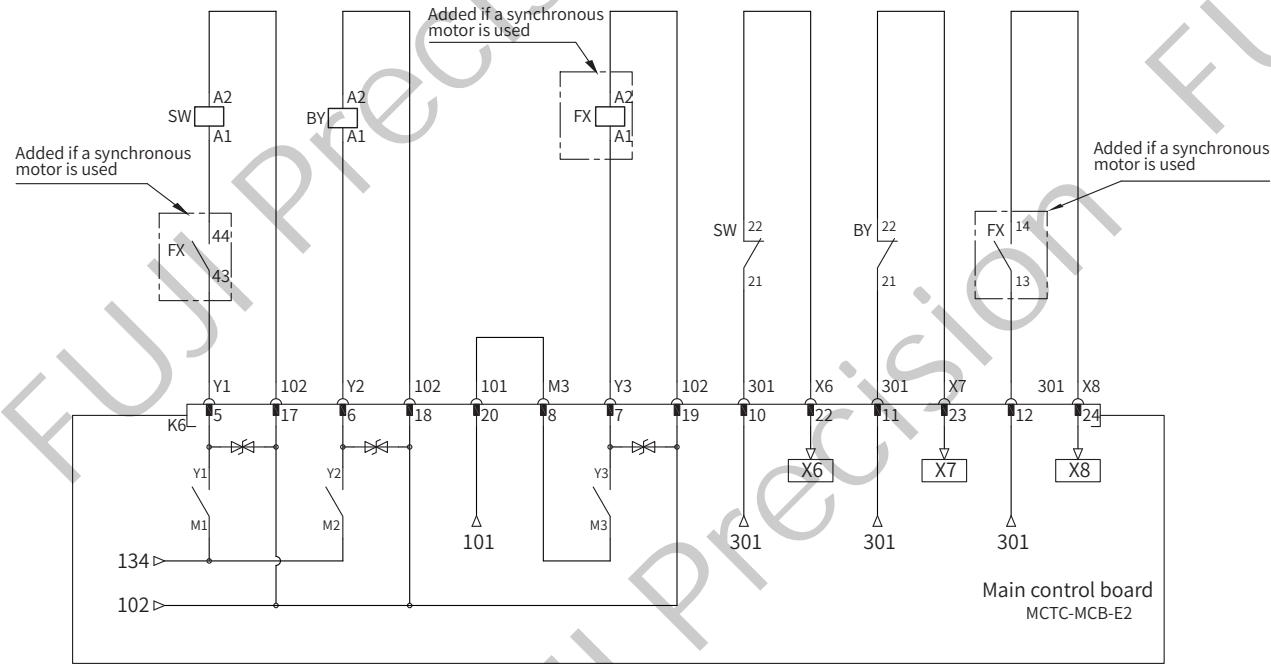

Notes:

1. The synchronous motor is equipped with a shorting motor stator contactor by default, while the asynchronous motor is not.
2. Y1, Y2 and Y3 are contactor control relays. The MCB-E2 has a built-in contactor coil current suppressor.

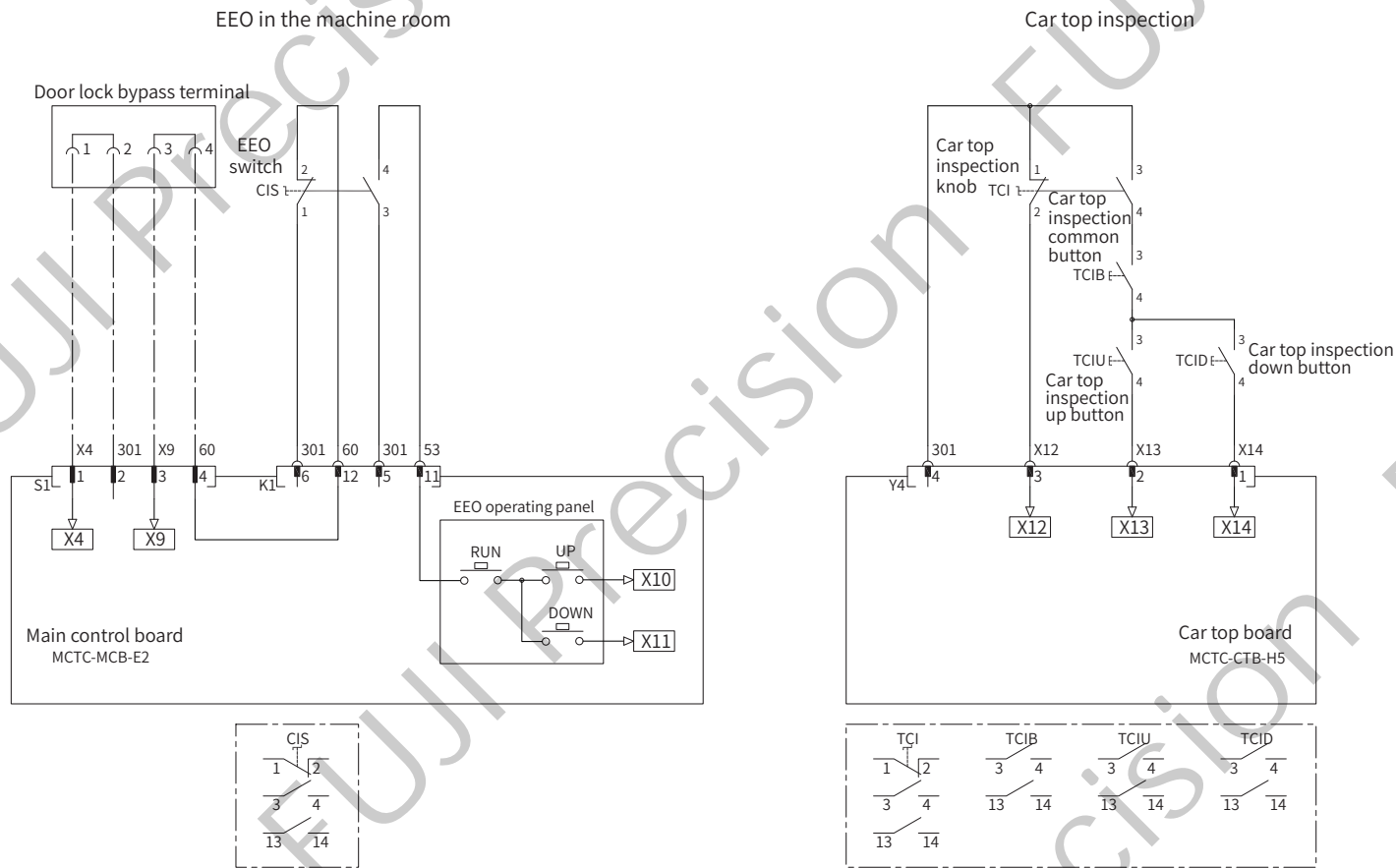

Notes:

1. The inspection speed is different from the EEO speed, meeting the requirements of Chinese standards.
2. After the bypass device starts, the machine room enters the EEO state. Then, the car top sound and light alarm device starts and outputs a sound and light alarm signal.



Car top lighting

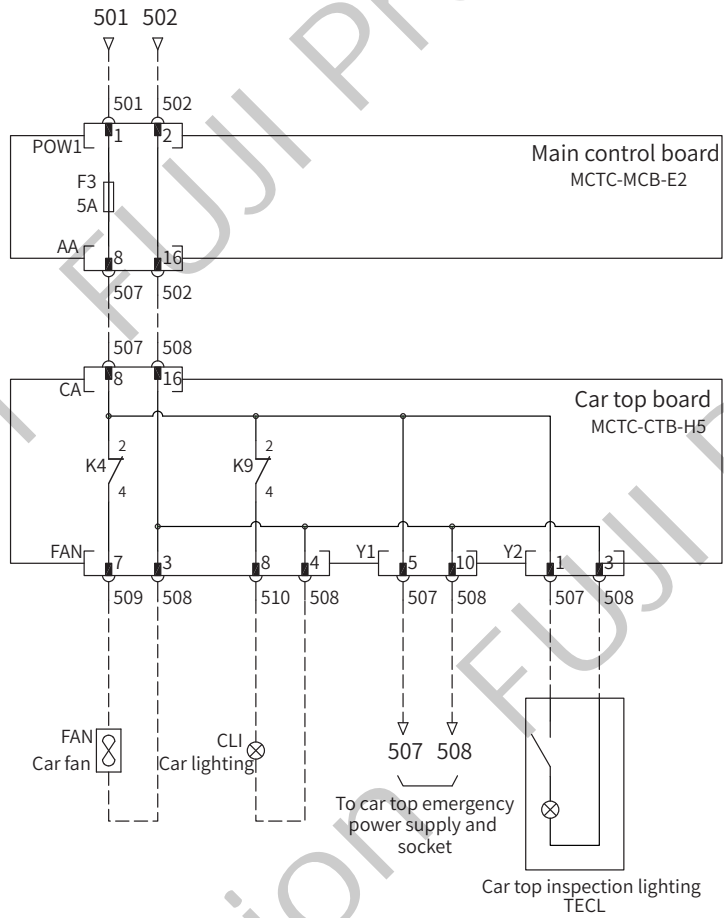

Shaft/Pit lighting

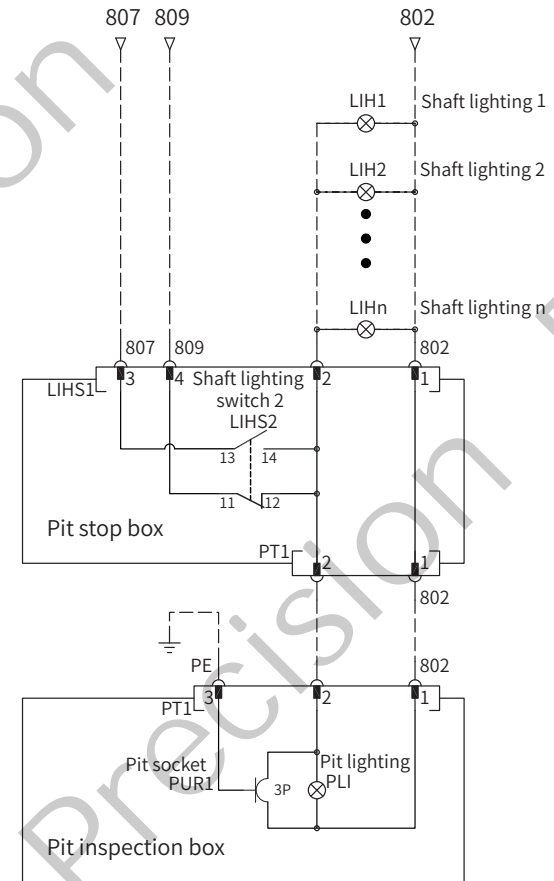

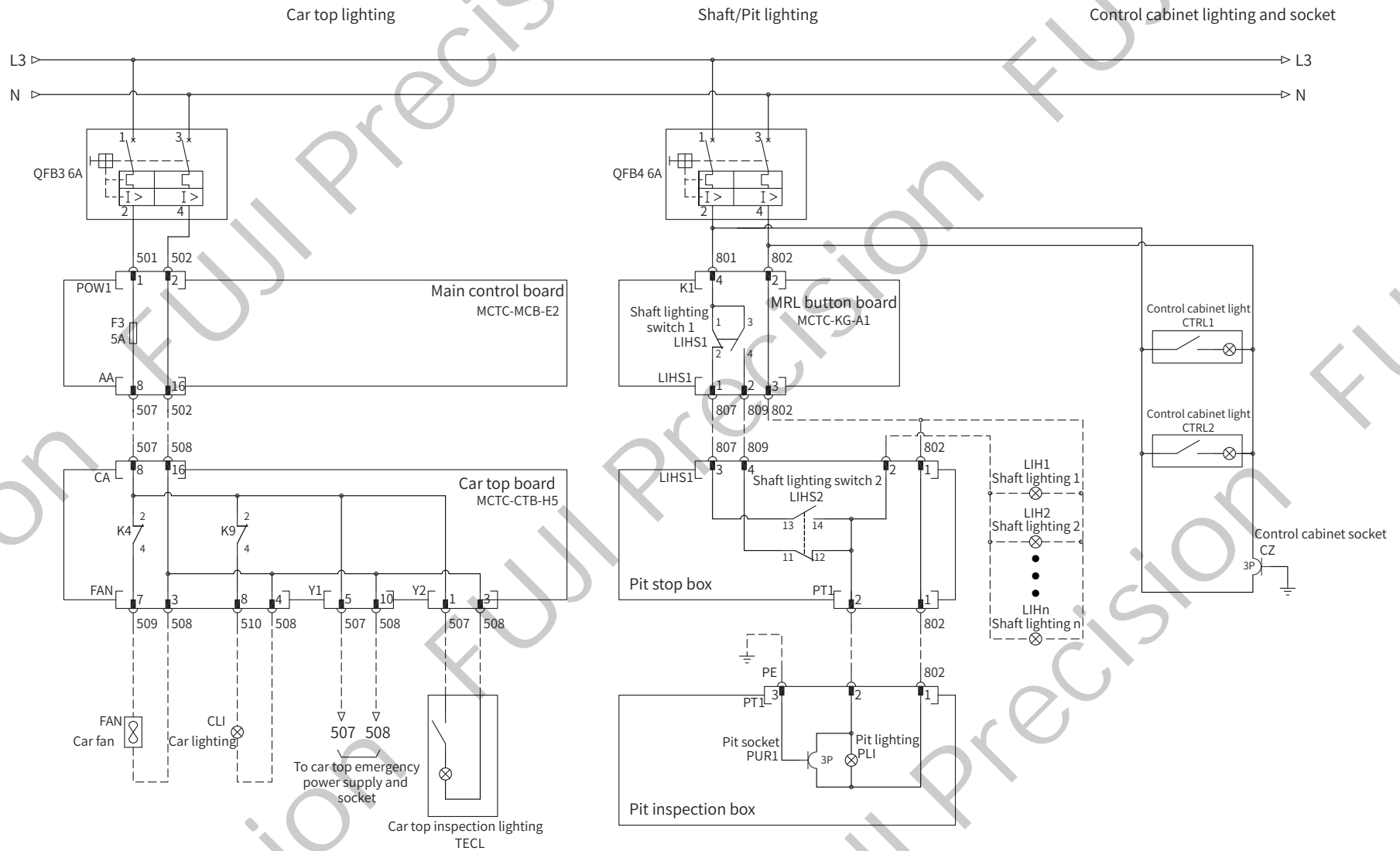

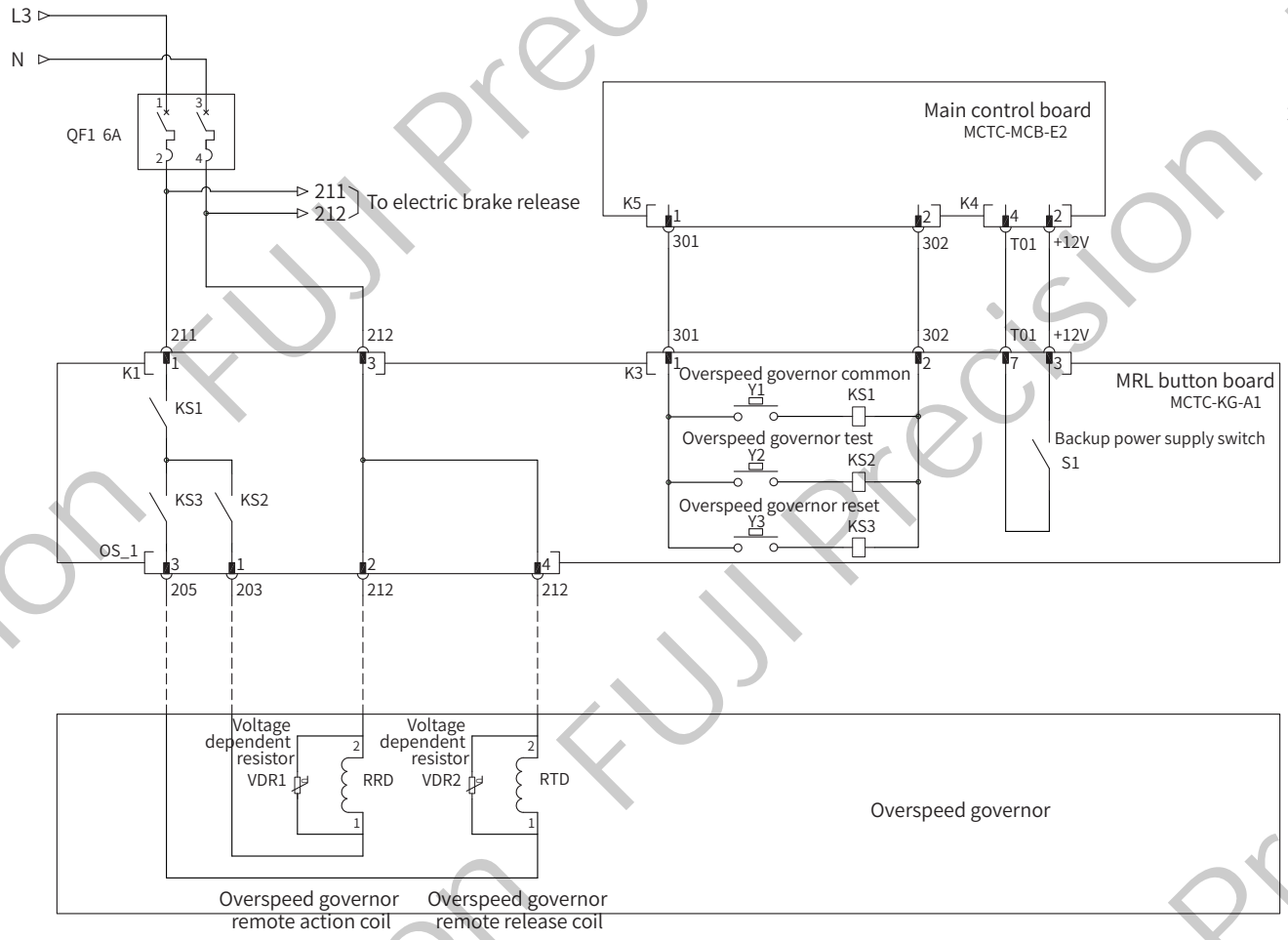

Notes:

1. At power failure, start the backup power supply to provide 12 VDC power to the MCTC-MCB-E2. The LEDs will light up and display the car position, running direction and running speed in a scrolling mode.
2. The MCTC-KG-A1 integrates the overspeed governor function buttons. Set the overspeed governor common button and connect it to terminal OS\_1 to avoid misoperations.

Indicator	Color	State Description
Brake release voltage output indicator	Green	Steady ON: There is a brake release voltage output.
		Steady OFF: There is no brake release voltage output.
Fault indicator	Red	Steady ON: Brake release output overload or short-circuit
		Steady OFF: Normal state
Battery indicator	Yellow	Steady ON: The battery is fully charged.
		Slow flashing: The battery is in the charging/discharging state.
		Quick flashing: The battery level is too low.
Door zone indicator	Blue	Steady ON: The elevator is in the door zone when the mains electricity fails.
		Steady OFF: The elevator is in the non-door zone when the mains electricity fails.

Terminal Type	Terminal Assignment	Function Description
220 VAC input	L	220 VAC input
	N	220 VAC input
Brake release voltage output	ZQ1+	Positive pole of brake release voltage
	ZQ2-	Negative pole of brake release voltage
24 V voltage output	24V	Positive pole of 24 V output
	COM	Negative pole of 24 V output
Door zone wire input	MQ+	High active input side of door zone wire
	MQ-	Low active input side of door zone wire
Door lock signal input	MS+	Positive pole of door lock signal input
	MS-	Negative pole of door lock signal input

Operate the electric brake release device as follows:

1. Pull out the BA cable plug (shaft safety cable) and insert it into the reserved BA1 socket in the MRL control cabinet.
2. This solution is suitable for the electric brake release operations at the failure of mains electricity.
  - ① When the mains electricity is normal, it charges the batteries.
  - ② When the mains electricity fails, implement the electric brake release using the buttons on the electric brake release device.
    - a. Press the Start and Common buttons simultaneously to release the brake when the elevator is in the non-door zone.
    - b. Press the Forced and Common buttons simultaneously to release the brake when the elevator is in the door zone.
3. After completion of the electric brake release, put the BA plug back to the interface board and BA1 socket to the original position. The elevator returns to the normal state.

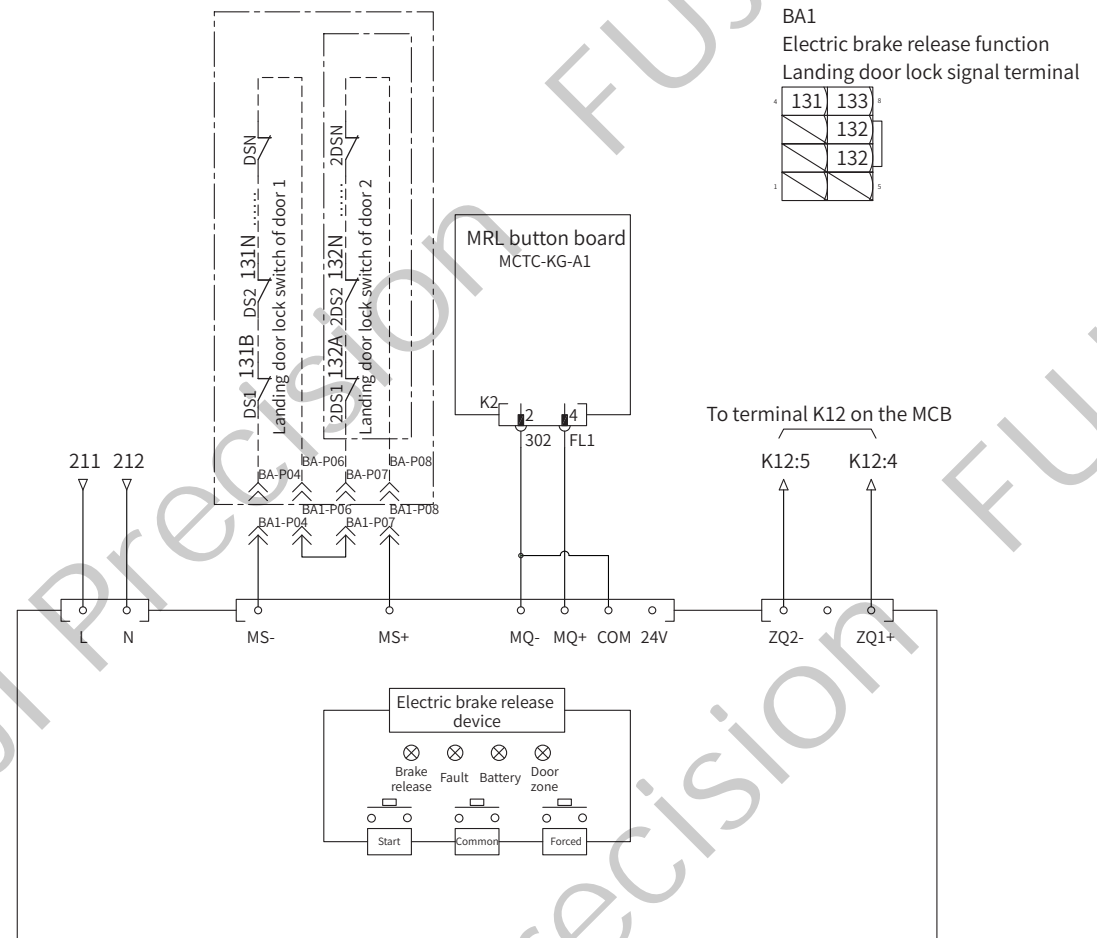

Notes:

1. The MCTC-ERB-A1 is suitable for brake devices whose startup voltage and operating voltage are not greater than 110 VDC and 80 VDC respectively.
2. Connect the electric brake release device to the door zone signal. The car top emergency power supply will power the door zone switches at power failure.
3. The door lock signal is used to judge whether the landing door is closed. When the door lock signal is not closed, the electric brake release device does not output a brake release voltage.

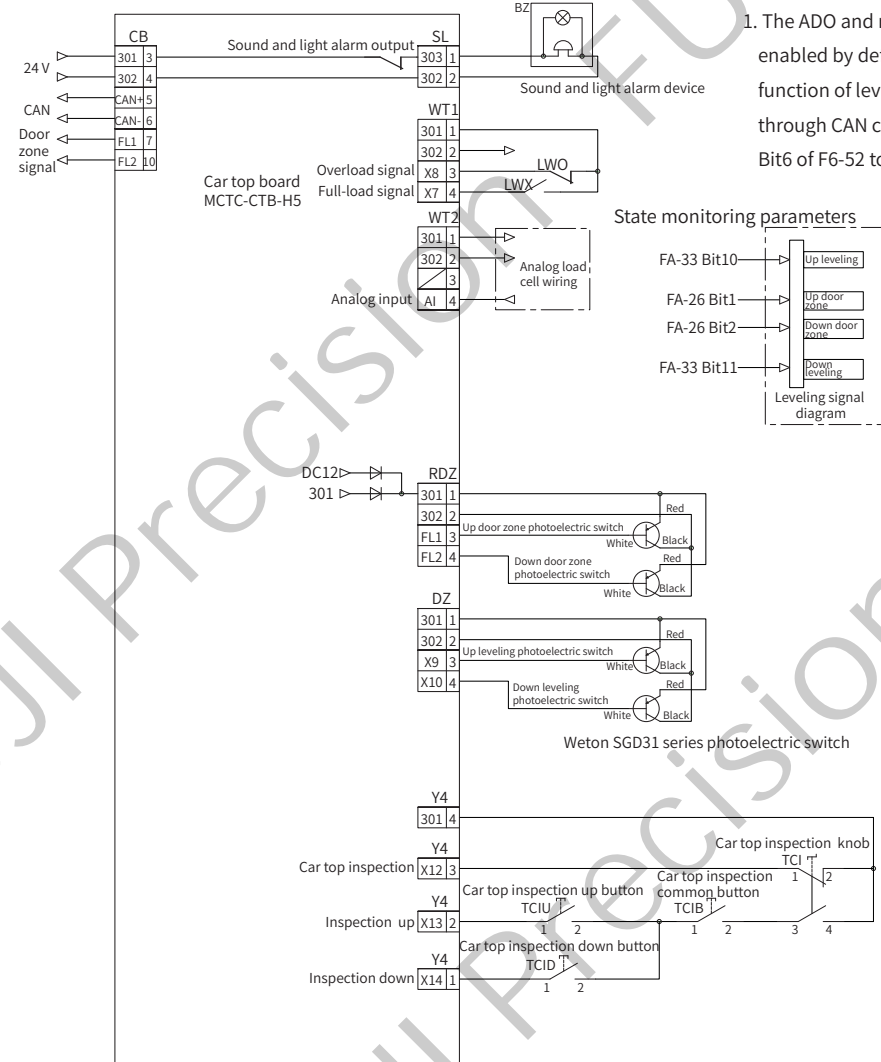
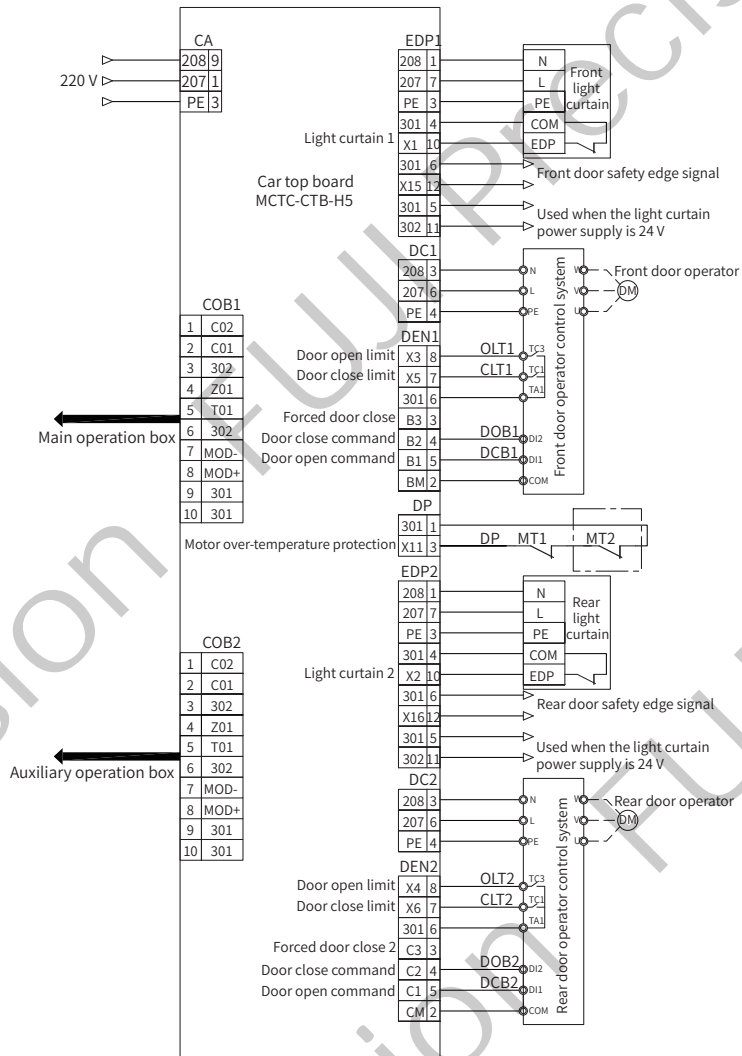

Notes:

1. The ADO and re-leveling functions are enabled by default. You can enable the function of leveling signal input/output through CAN communication by setting Bit6 of F6-52 to 1.

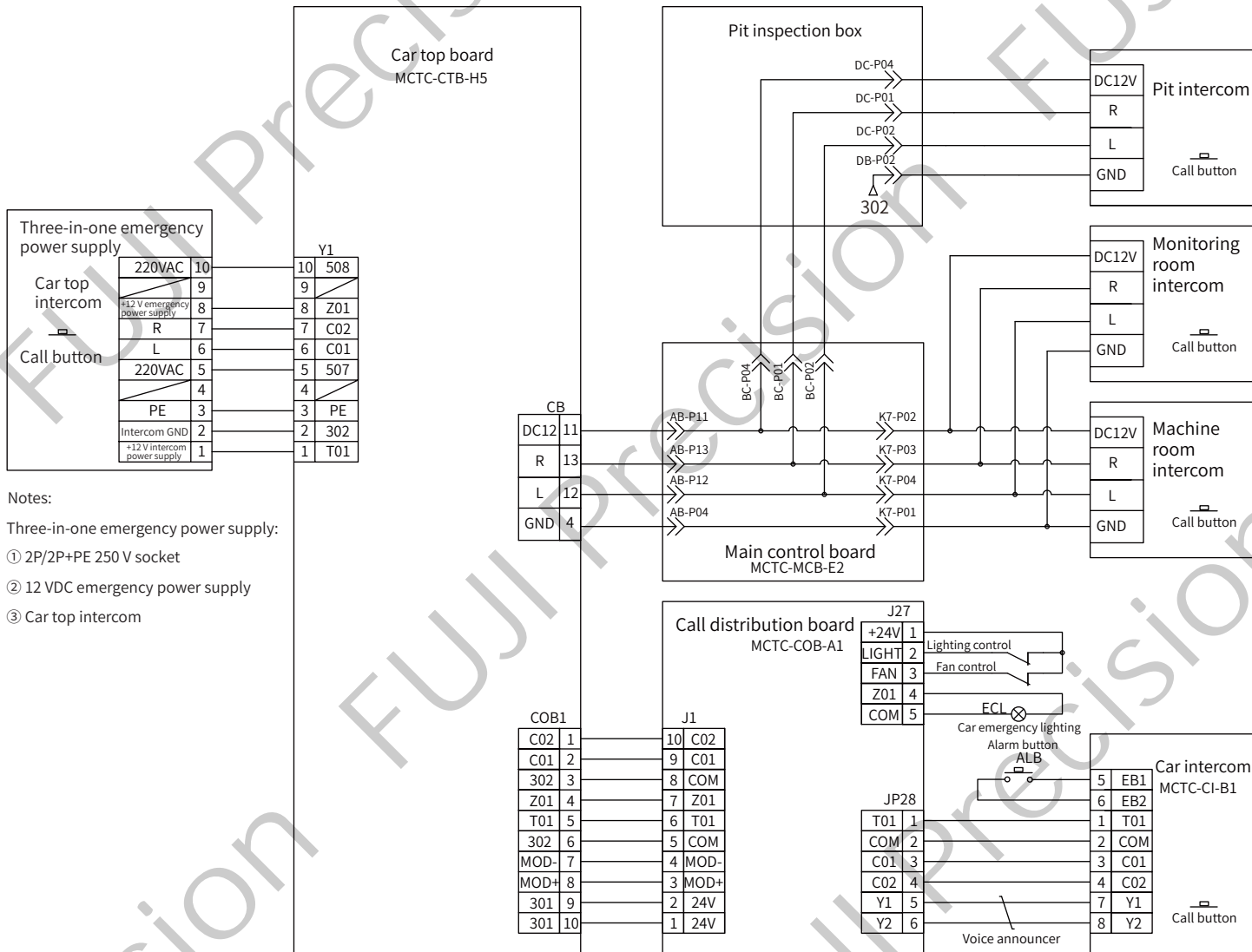

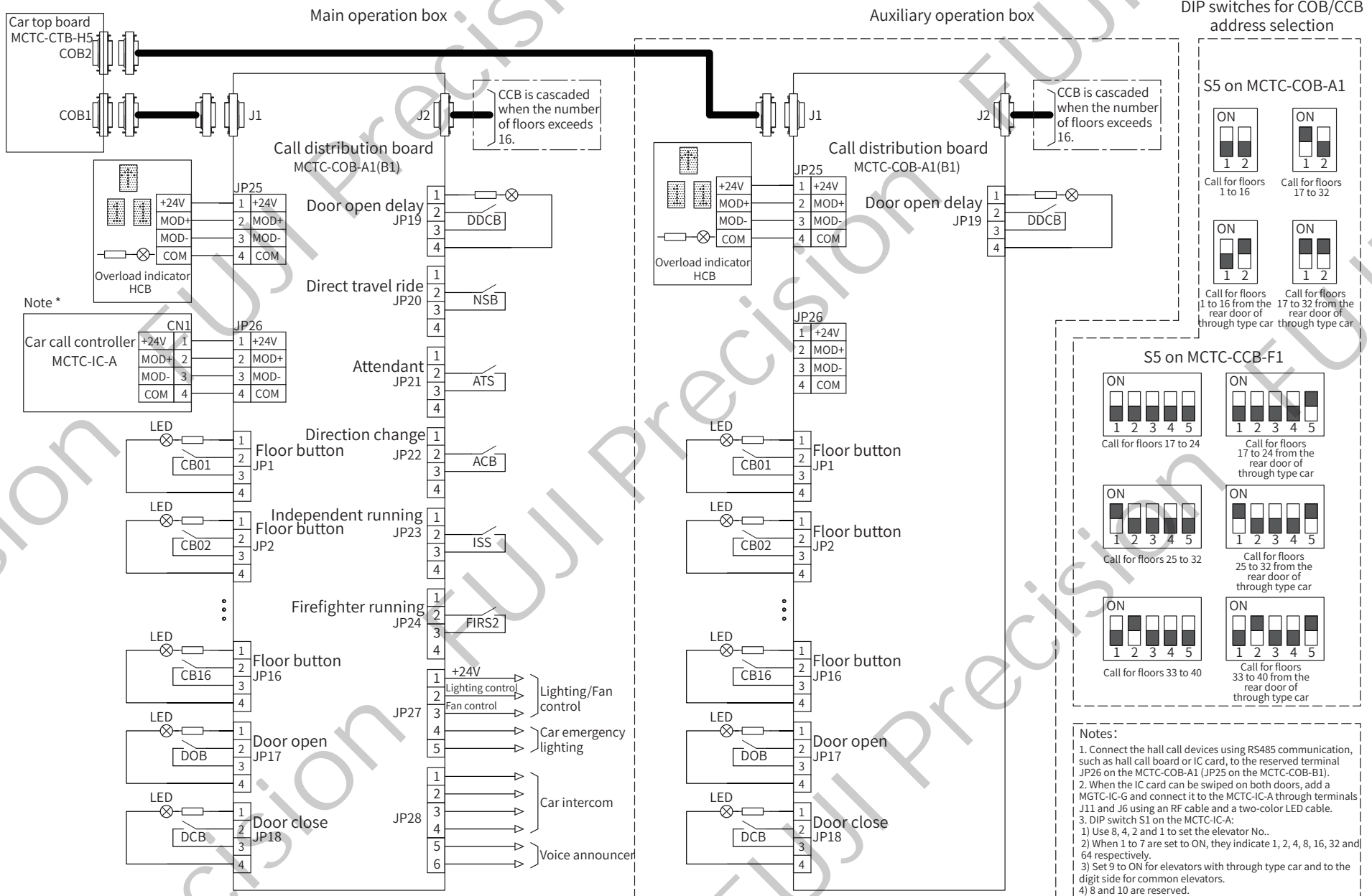

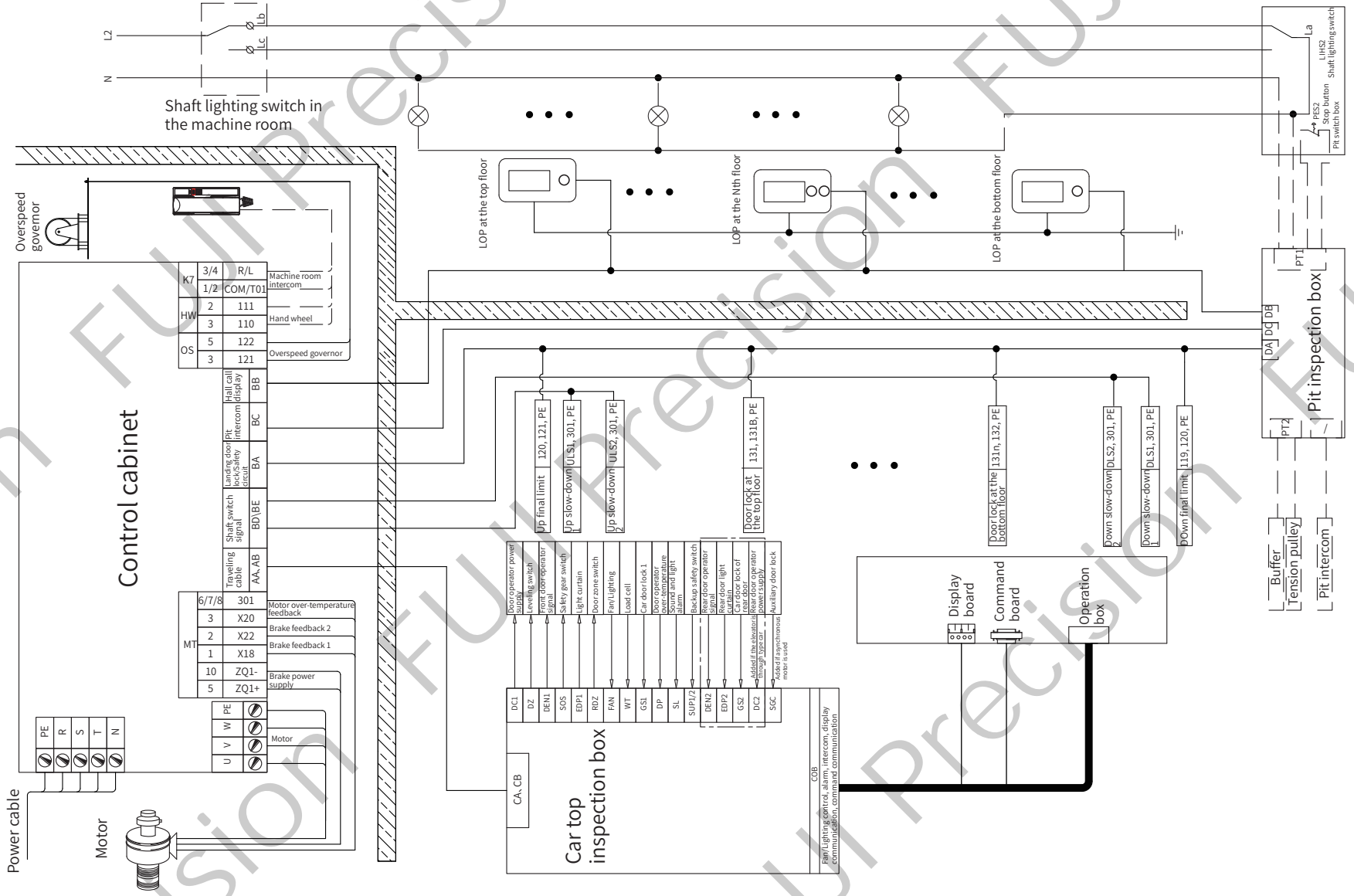



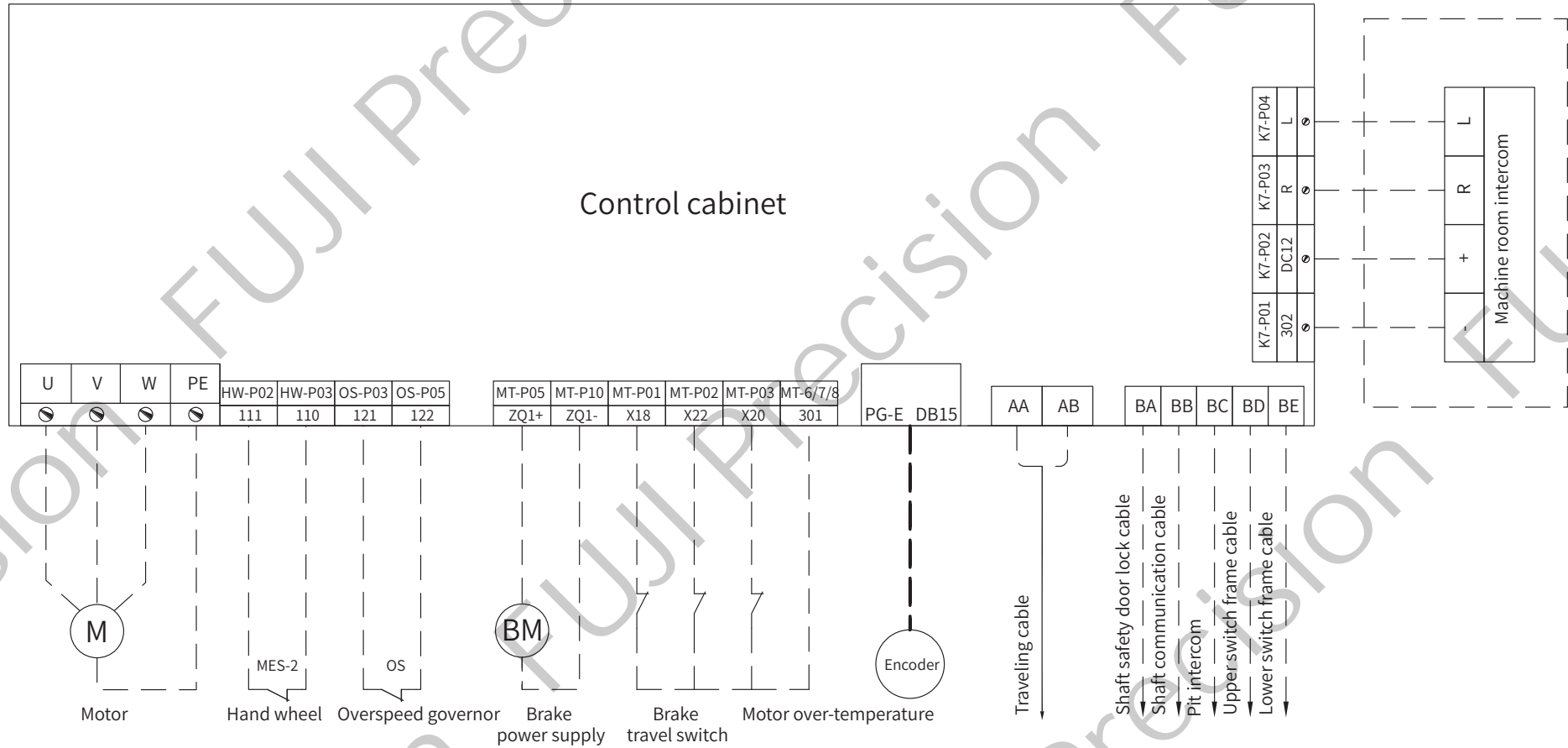

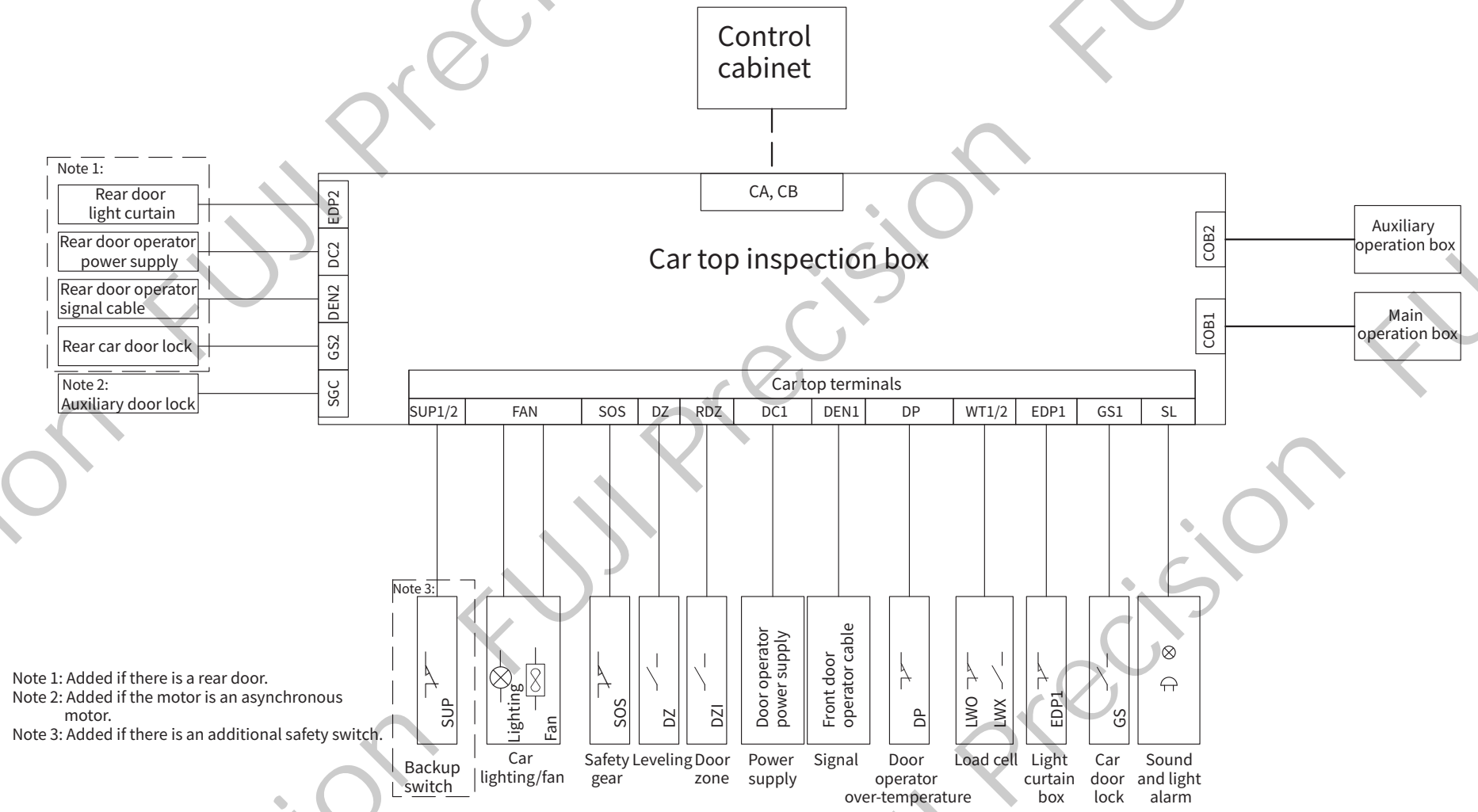

Note 1:

- Rear door light curtain
- Rear door operator power supply
- Rear door operator signal cable
- Rear car door lock

Note 2:

- Auxiliary door lock

Note 3:

- Backup switch

Note 1: Added if there is a rear door.  
 Note 2: Added if the motor is an asynchronous motor.  
 Note 3: Added if there is an additional safety switch.

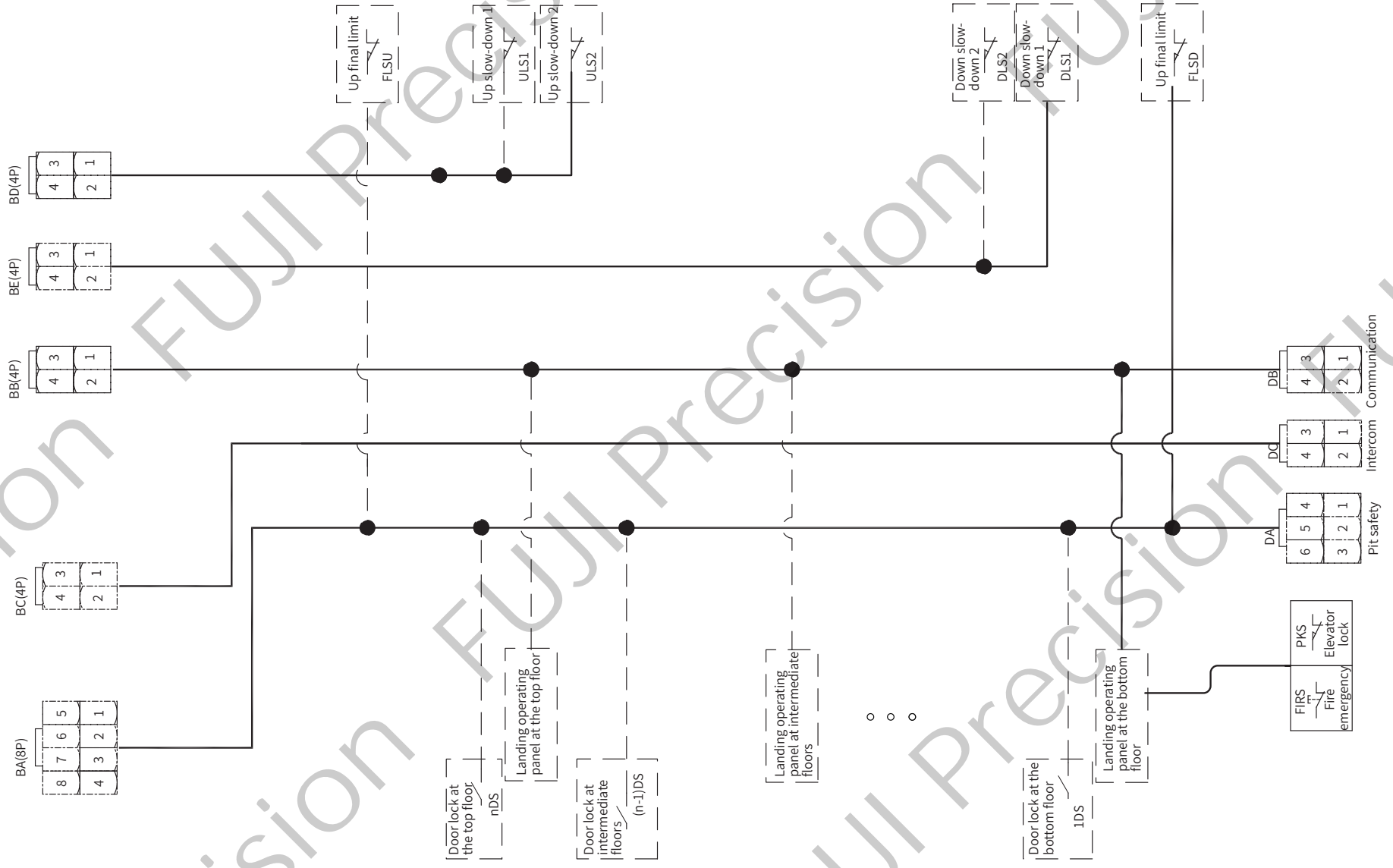

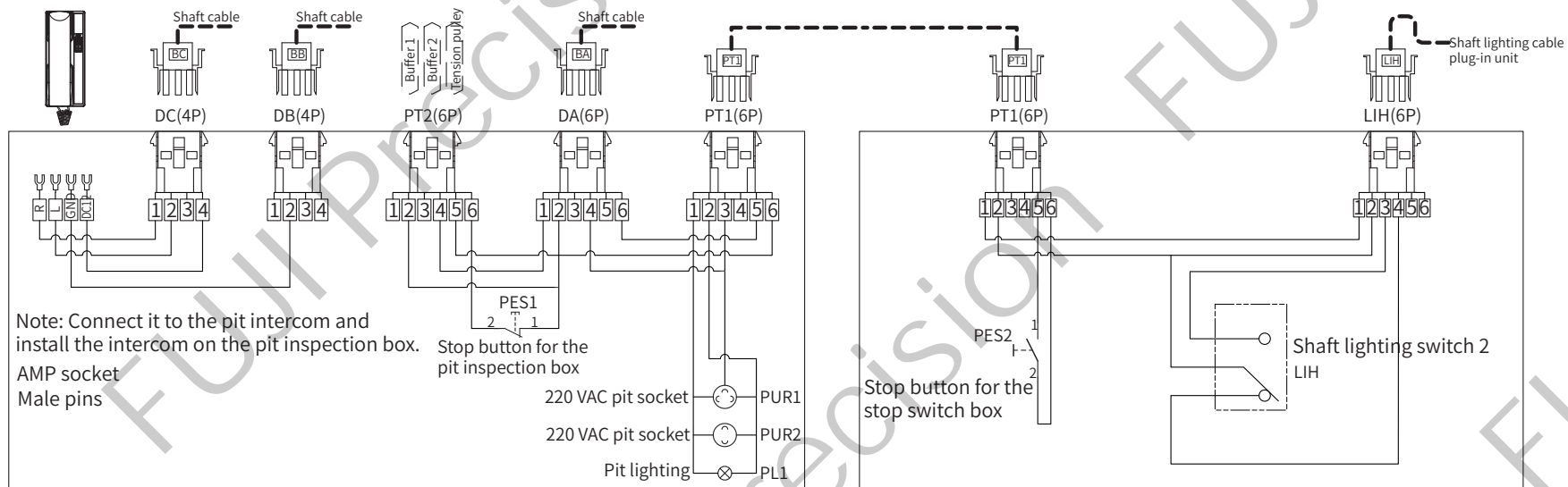

Note: Connect it to the pit intercom and install the intercom on the pit inspection box.  
AMP socket  
Male pins

Stop button for the pit inspection box

220 VAC pit socket PUR1  
220 VAC pit socket PUR2  
Pit lighting PL1

Stop button for the stop switch box

Shaft lighting switch 2  
LIH

Pit inspection box (MBT-PIB-A22) terminals

Pit switch box (MBT-PSB-A12) terminals

DA(6P)	
1	119
2	118
3	
4	PE
5	
6	111

PT1(6P)	
1	802
2	805
3	PE
4	
5	111
6	112

PT2(6P)	
1	
2	118
3	PE
4	119
5	112
6	113

DB(4P)	
1	
2	302
3	
4	

DC(4P)	
1	R
2	L
3	
4	DC12

LIH(6P)	
1	802
2	805
3	803
4	804
5	
6	PE

PT1(6P)	
1	802
2	805
3	PE
4	
5	111
6	112

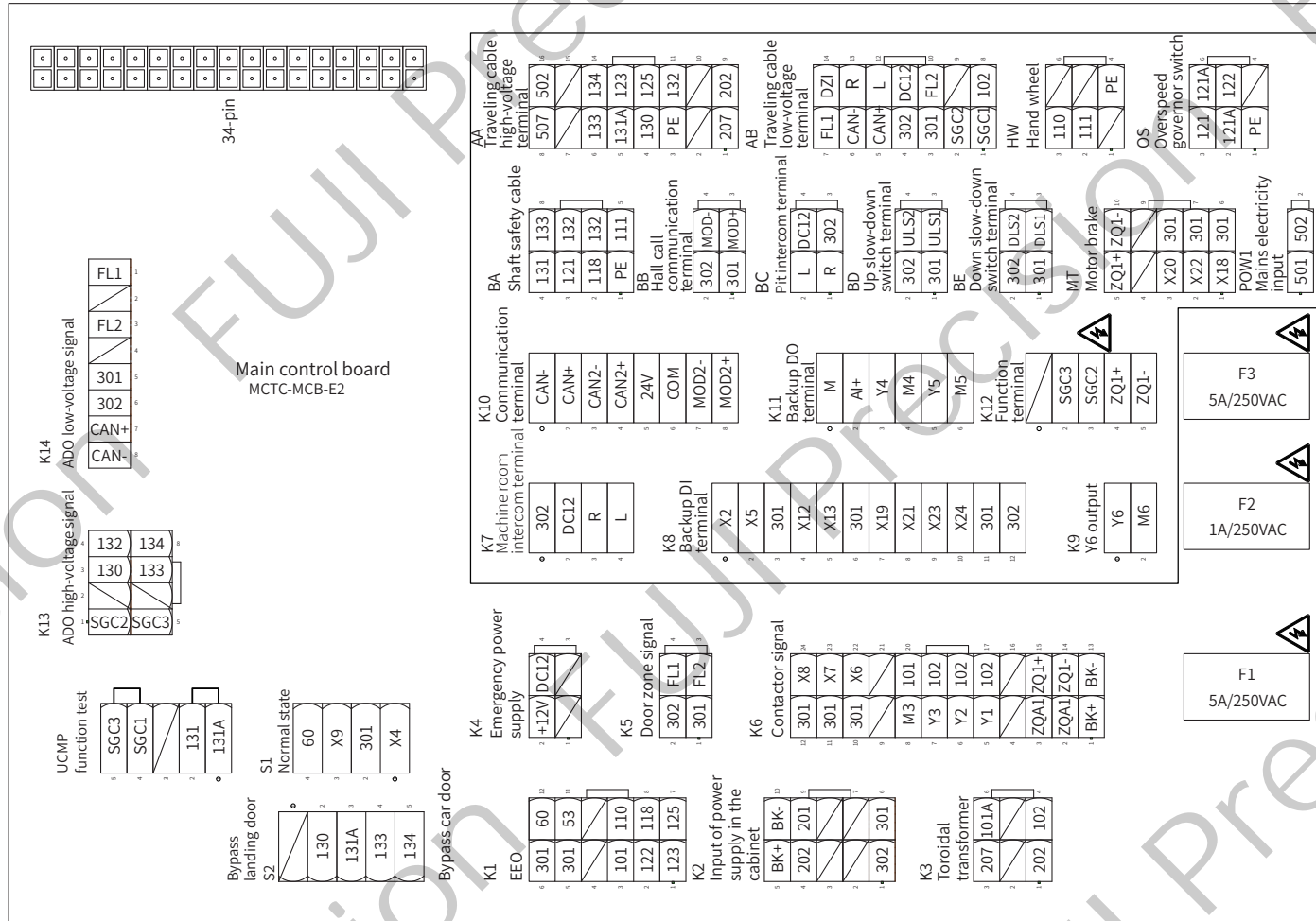

List of input/output (I/O) terminals

Terminal	Definition	Position No.
X1	Up door zone	MCB-K5:4
X2	Backup	MCB-K8:1
X3	Down door zone	MCB-K5:3
X4	Bypass	MCB-S1:1
X5	Backup	MCB-K8:2
X6	RUN contactor feedback	MCB-K6:22
X7	Brake contactor feedback	MCB-K6:23
X8	Shorting motor stator contactor feedback	MCB-K6:24
X9	EEO	MCB-S1:3
X10	EEO up	/
X11	EEO down	/
X12	Backup	MCB-K8:4
X13	Backup	MCB-K8:5
X14	Up slow-down 1	MCB-BD:3
X15	Down slow-down 1	MCB-BE:3
X16	Up slow-down 2	MCB-BD:4
X17	Down slow-down 2	MCB-BE:4
X18	Brake micro-gap switch feedback 1	MCB-MT:1
X19	Backup	MCB-K8:7
X20	Motor over-temperature protection (added if the motor overheats)	MCB-MT:3
X21	Backup	MCB-K8:8
X22	Brake micro-gap switch feedback 2	MCB-MT:2
X23	Emergency evacuation completion feedback (added if the ARD function is configured)	MCB-K8:9
X24	Backup	MCB-K8:10
X25	Safety circuit detection	MCB-BA:4
X26	Door lock 1 shorting detection	MCB-BA:4
X27	Door lock circuit detection	MCB-AA:14
X28	Door lock 2 shorting detection	MCB-AA:6
Y1	RUN contactor	MCB-K6:5
M1		/
Y2	Brake contactor	MCB-K6:6
M2		/
Y3	Shorting motor stator contactor (added for the synchronous motor)	MCB-K6:7
M3		/
Y4	Fire linkage output (backup)	MCB-K11:3
M4		MCB-K11:4
Y5	Backup	MCB-K11:5
M5		MCB-K11:6
Y6	ARD output (backup)	MCB-K9:1
M6		MCB-K9:2

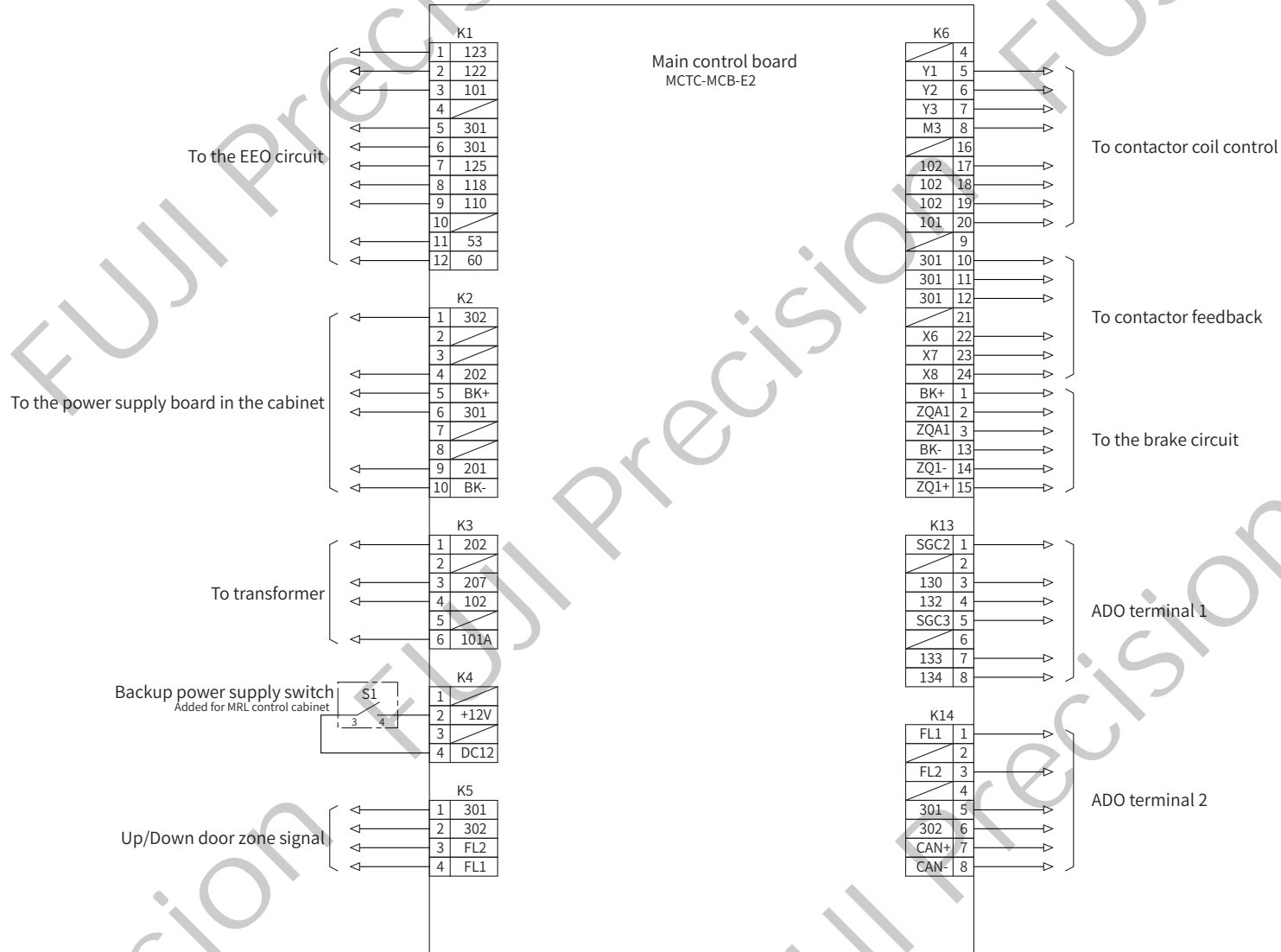

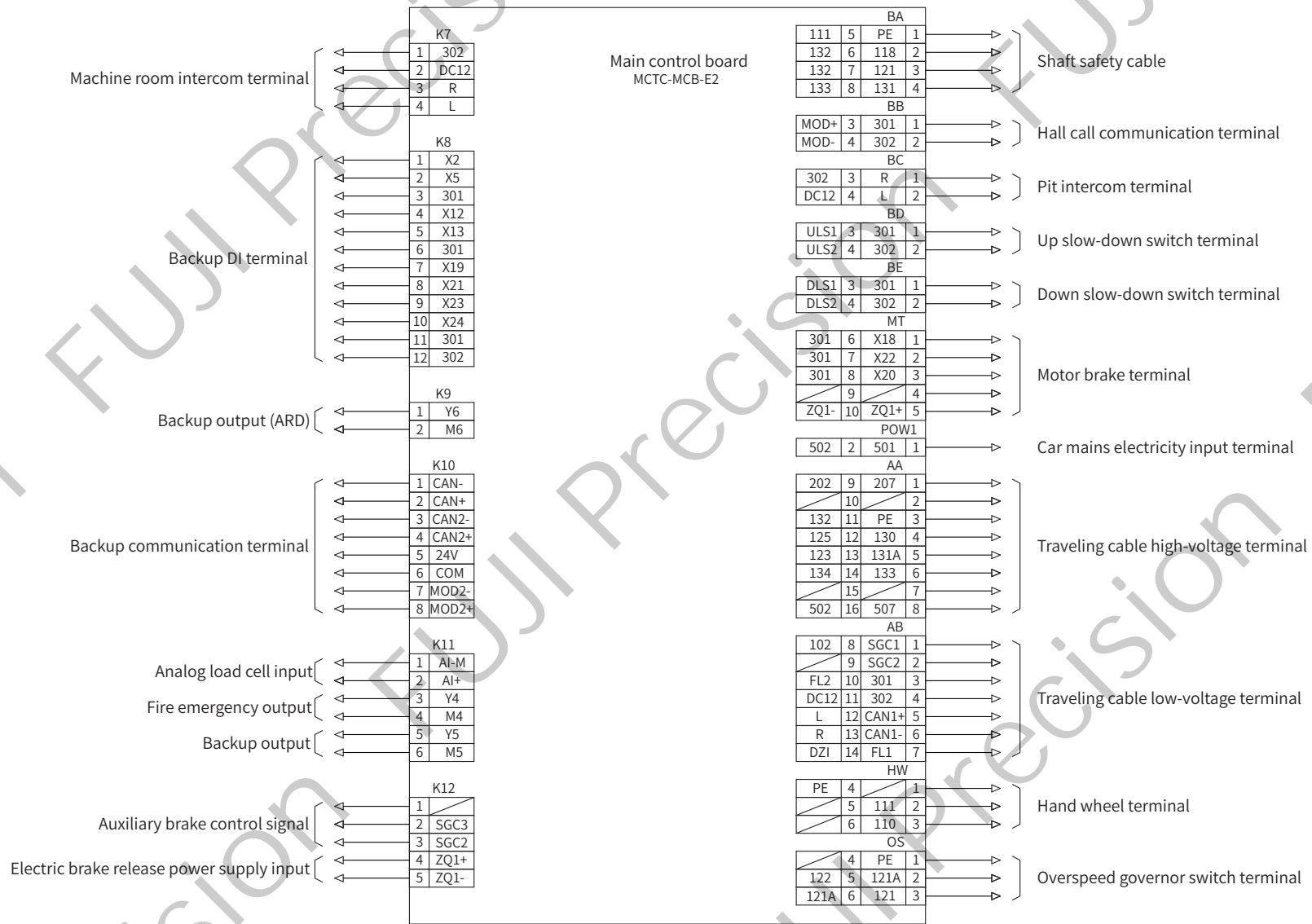

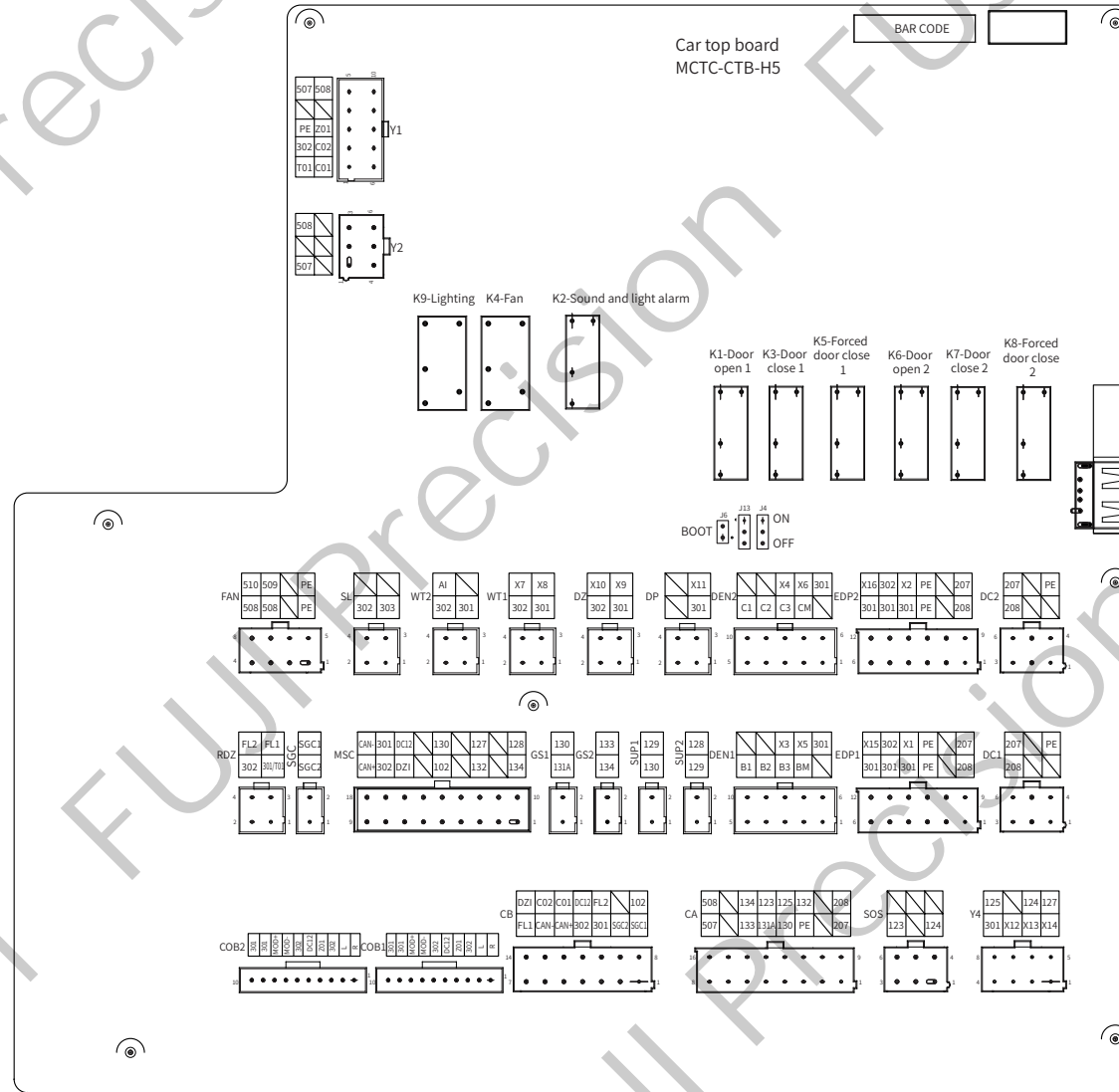



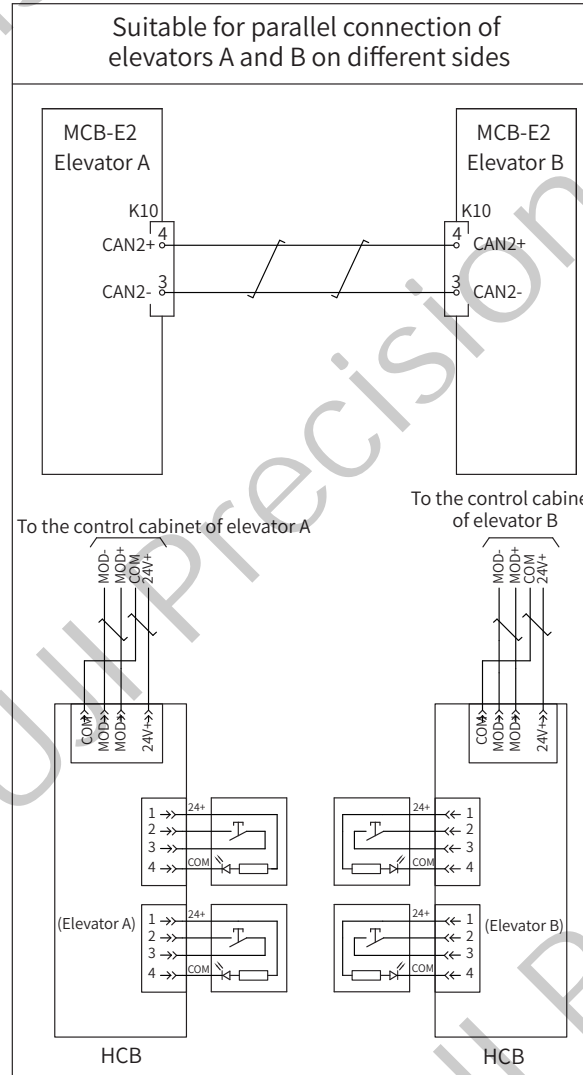
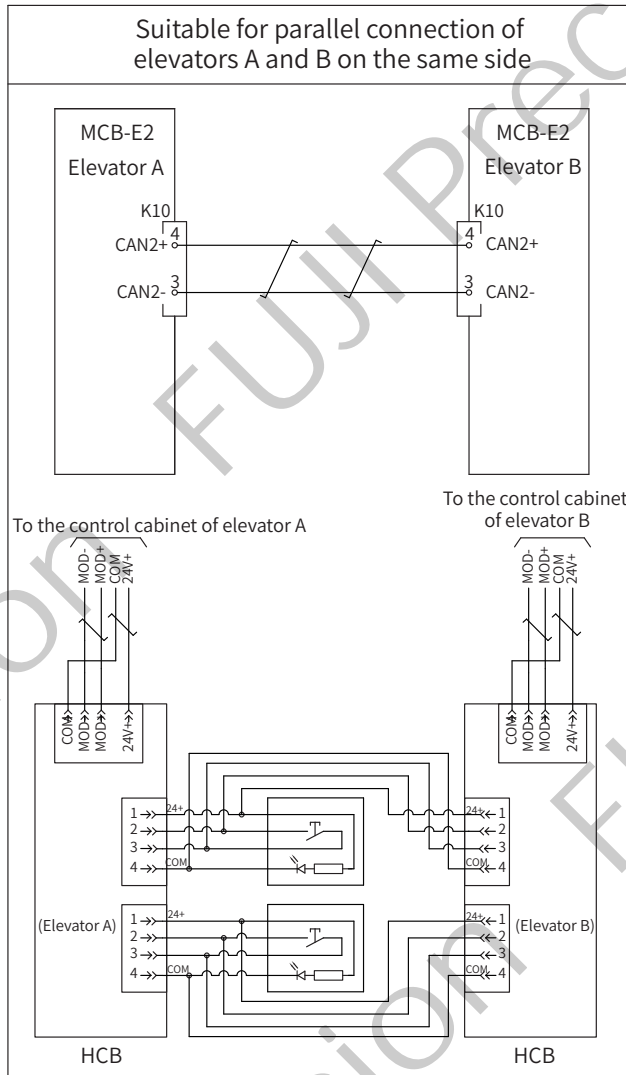

Notes:

1. Set the HCB addresses according to physical addresses.
2. Setting of group control parameters:
  - 1) Number of elevators in group control: F6-07 = 2
  - 2) Elevator No.:
    - Master elevator: F6-08 = 1
    - Slave elevator: F6-08 = 2
- 3) Program selection:
  - Bit3 of F6-09 = 1 (parallel/group control implemented through CAN2)

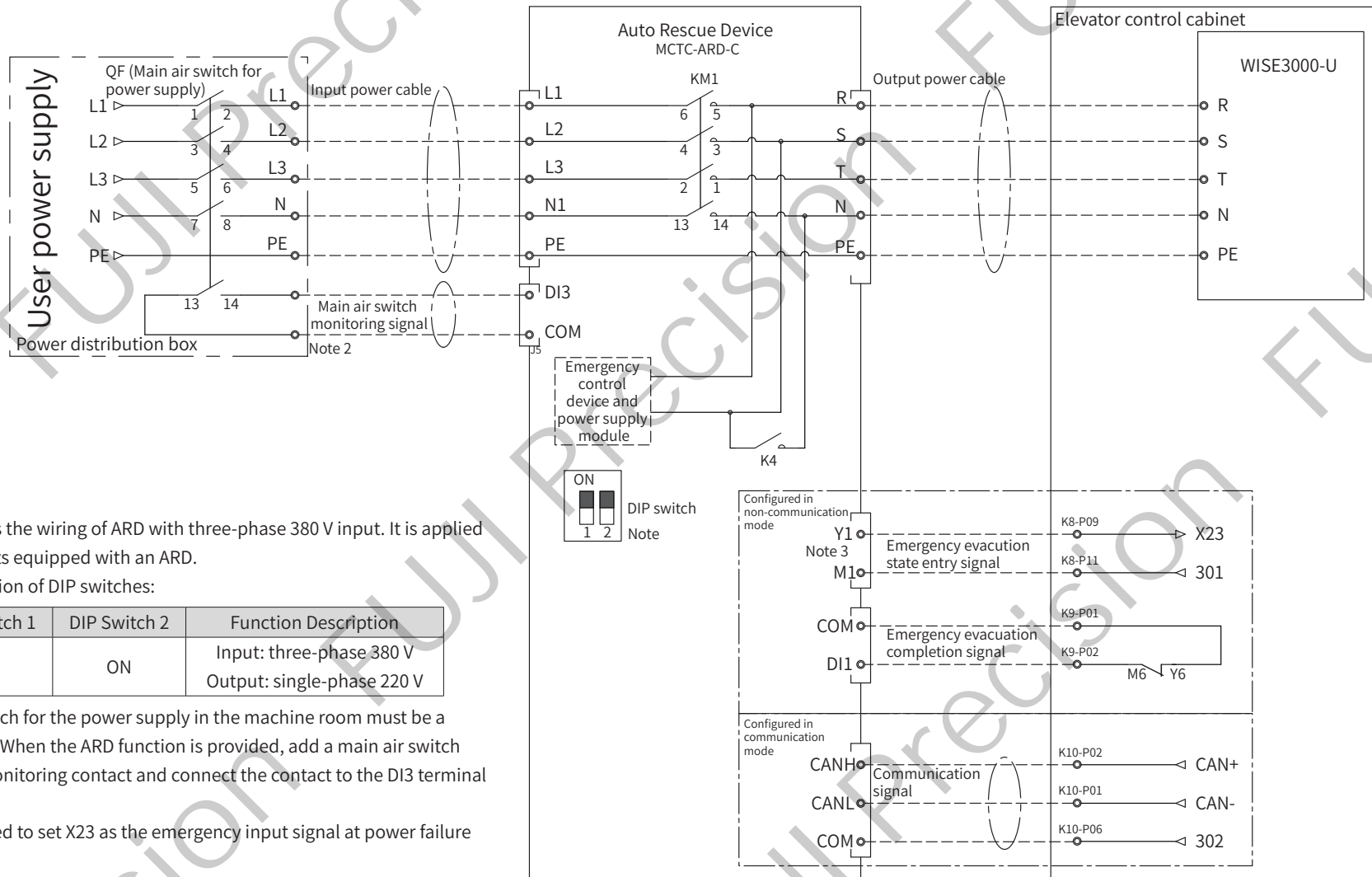

Notes:

1. This figure shows the wiring of ARD with three-phase 380 V input. It is applied to control cabinets equipped with an ARD.
2. Position description of DIP switches:
 

DIP Switch 1	DIP Switch 2	Function Description
ON	ON	Input: three-phase 380 V Output: single-phase 220 V
3. The main air switch for the power supply in the machine room must be a level 4 air switch. When the ARD function is provided, add a main air switch disconnection monitoring contact and connect the contact to the DI3 terminal on the ARD.
4. It is recommended to set X23 as the emergency input signal at power failure (F5-23 = 27).

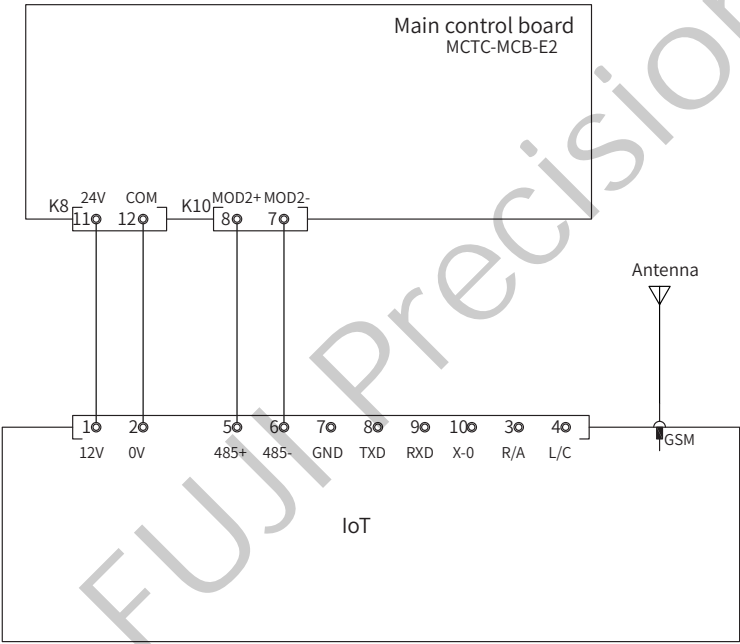

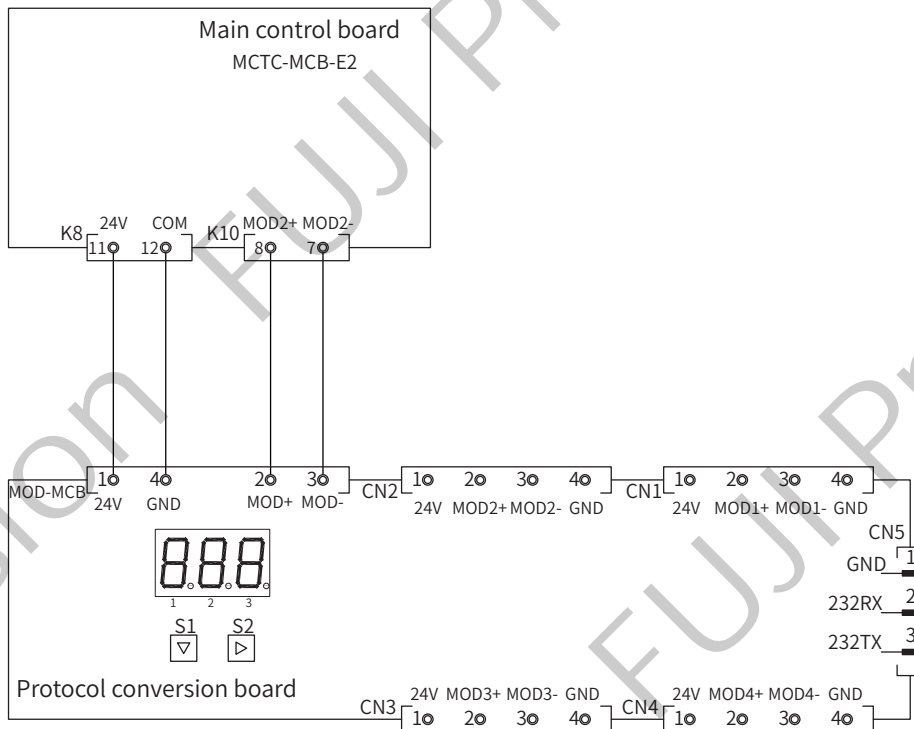

Notes:

1. Correspondence between LED displays and port protocols

① Correspondence between LED 1 displays and communication ports:

LED 1 Display	1.	2.	3.	4.	5.
Communication Port	MOD1	MOD2	MOD3	MOD4	232

② Correspondence between LED 2/3 displays and port protocols:

LED 2/3 Display	01	02	03	04	05
Port Protocol	Open protocol A - connected to the external RS485 device	Open protocol A - connected to the external RS485 device	Inovance's IoT protocol - connected to the external IoT device	Residential monitoring	Connected to the external host controller through RS232 communication. MOD2 is inactive by default.

2. The menu has two levels:

Level I: Fxx

Level II: setting value

- ① Press " ↓ " key to enter the level I menu and perform switchover in this menu, and press " → " to enter the level II menu.
- ② In level II menu, " ↓ " key is used to change values, and " → " key is used to confirm the value setting and return to the level I menu.

3. LED displays

- ① " --- " is displayed when the self-authentication of the encryption system fails, and " === " is displayed when the system authentication fails.
- ② If a fault occurs, fault codes such as E01 and E02 will be displayed. E01 indicates that communication with the MCB fails, and E02 indicates that communication with external devices fails.

Fault Display	Meaning
E01	The authentication of the unencrypted protocol conversion board and MCB fail.
E02	The communication between the protocol conversion board and the MCB fails.
E03	The communication between the protocol conversion board and external devices fails.
E04	There are communication data, but all the data are incorrect.

- 4. When both protocol conversion board and IoT module are equipped, connect the IoT communication to port MOD3 on the protocol conversion board.
- 5. When the protocol conversion board is used for residential monitoring, use port MOD4 for the residential monitoring board communication network and connect the MOD-MCB to the MCB of each elevator and port 232 to the host controller.

Notes:

1. The expansion of up to 14 inputs/outputs (optional) are supported.
2. Set the expansion board addresses using the DIP switches.
  - ① When all the DIP switches are OFF, this expansion board is on the car top. Terminal J7 is reserved.
  - ② When K1 is set to ON (1) and other positions are set to OFF, this expansion board is in the machine room. It can expand one-channel hall calls from the rear door to realize the through type car control of 40 floors. Terminal J7 is used as an expanded communication interface.
3. Set the functions of expansion board terminals in FD-11 to FD-50.

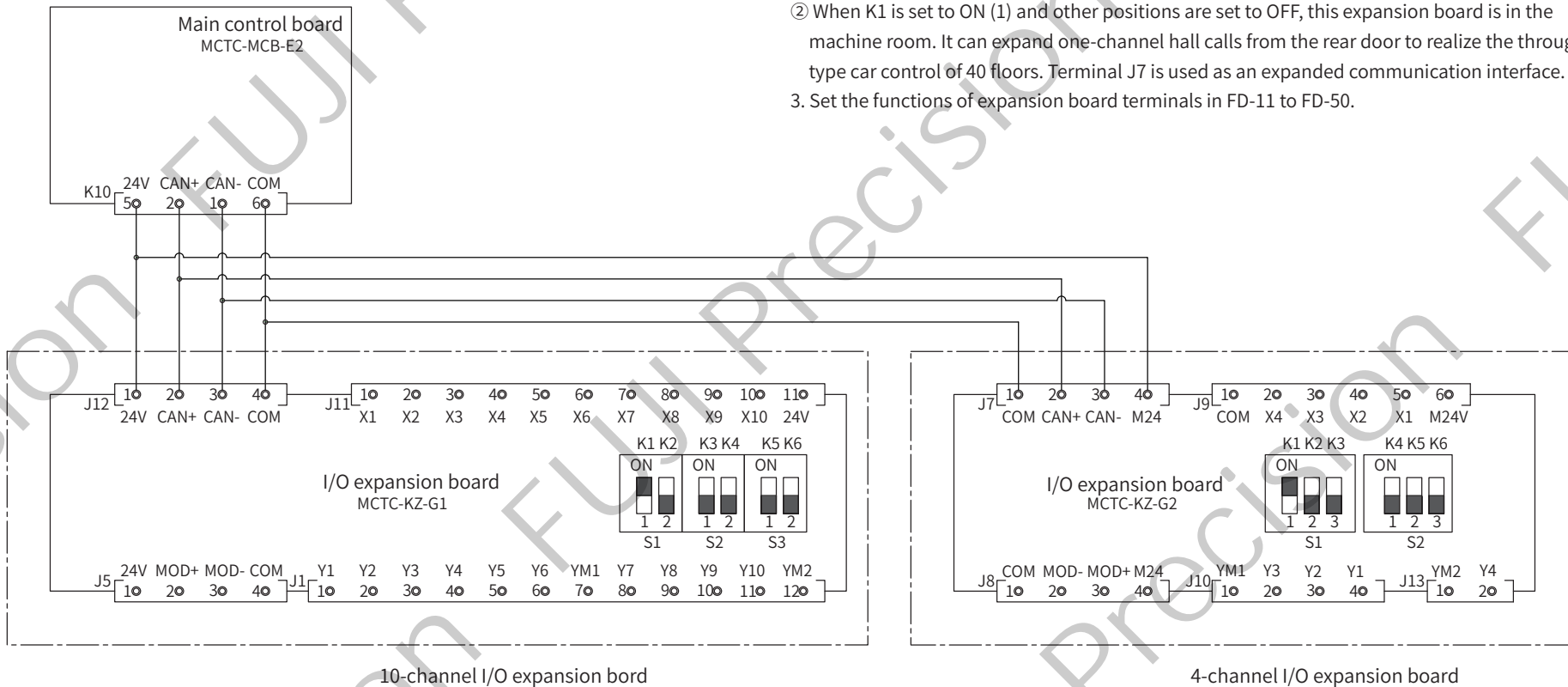

10-channel I/O expansion board

4-channel I/O expansion board